

# 高纯焊接接头

## 特征

1. 弯头/流道圆滑过渡，降低流道阻力，确保流体平稳流动
2. 加工精确，直径与Tube管直径匹配
3. 焊接端口平直，无毛刺
4. 可手动或自动焊接
5. 流道进行电解抛光，其表面粗糙度可达Ra 0.25 $\mu$ m(10 $\mu$ in.)
6. Tube管壁厚均匀，提高焊接的可重复性



## EP 微型焊接接头

### 特征:

紧凑的结构设计

尺寸范围: 1/8"至1/2", 6mm至12mm

适用于小型化的管道系统

## MR 微型变径直通过接头

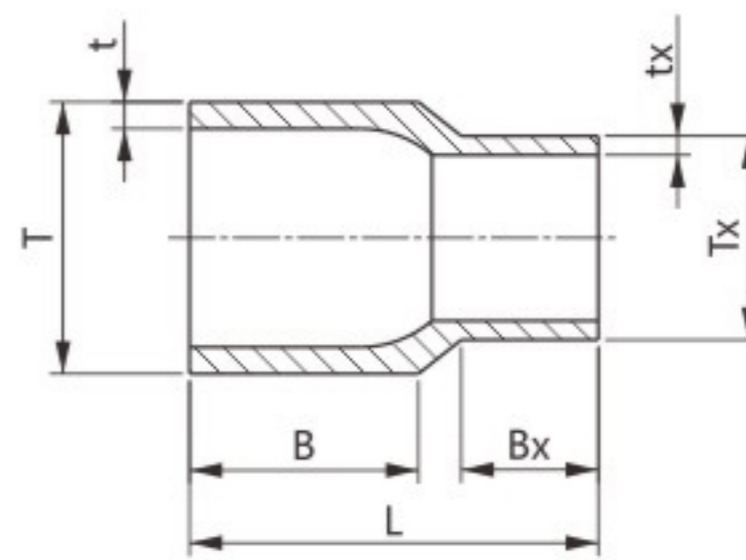
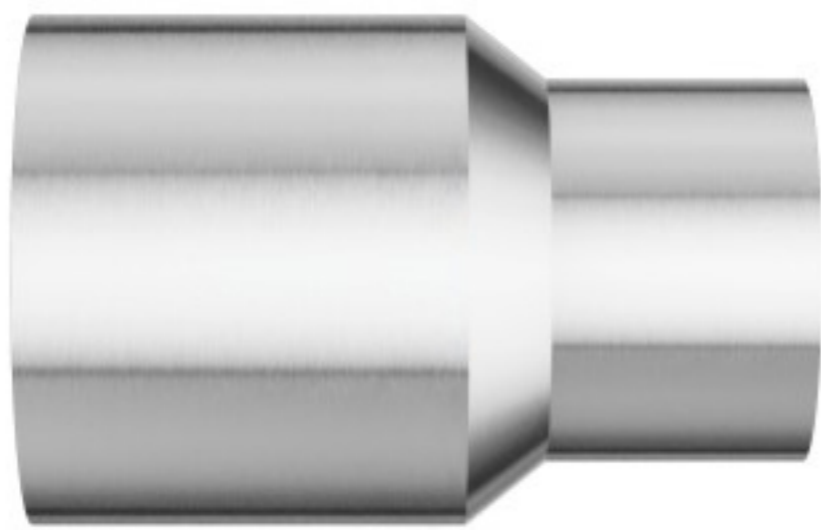

### 英制

产品型号	T-Tube管 外径(in.)	t-壁厚 (in.)	Tx-Tube管 外径(in.)	tx-壁厚 (in.)	尺寸 (mm)			工作压力 psig (bar)
					L	B	Bx	
MR42S	1/4	0.035	1/8	0.028	19.1	10.7	6.4	5100(351)
MR64S	3/8	0.035	1/4	0.035	19.1	10.7	6.4	3300(227)
MR84S	1/2	0.049	1/4	0.035	19.1	10.7	6.4	3700(254)
MR86S	1/2	0.049	3/8	0.035	19.1	10.7	6.4	3300(227)

**ME**  
微型90°弯头

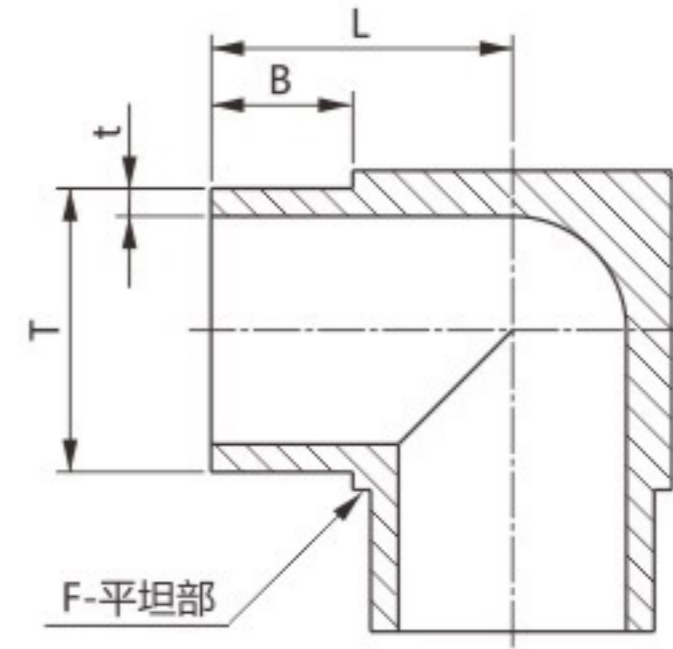

**英制**

产品型号	T-Tube管 外径(in.)	t-壁厚 (in.)	尺寸 (mm)			工作压力 psig (bar)
			L	B	F	
ME2S	1/8	0.028	10.4	6.4	7.9	8500(586)
ME4S	1/4	0.035	10.4	6.4	7.9	5100(351)
ME6S	3/8	0.035	11.9	6.4	11.1	3300(227)
ME8S	1/2	0.049	13.5	6.4	14.3	3700(254)

**公制**

产品型号	T-Tube管 外径(mm)	t-壁厚 (mm)	尺寸 (mm)			工作压力 psig (bar)
			L	B	F	
ME6MS	6	1.0	10.4	6.4	7.9	6095(420)
ME8MS	8	1.0	11.9	6.4	11.1	4499(310)
ME10MS	10	1.0	11.9	6.4	11.1	3483(240)
ME12MS	12	1.0	13.5	6.4	14.3	2902(200)

## ME 微型变径90°弯头

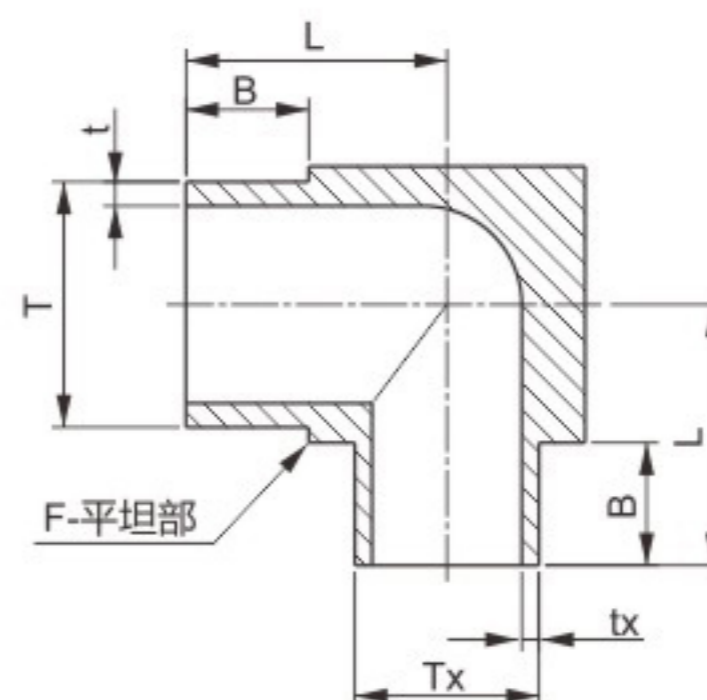

### 英制

产品型号	T-Tube管 外径(in.)	t-壁厚 (in.)	Tx-Tube管 外径(in.)	tx-壁厚 (in.)	尺寸 (mm)			工作压力 psig (bar)
					L	B	F	
ME64S	3/8	0.035	1/4	0.035	11.9	6.4	11.1	3300(227)
ME84S	1/2	0.049	1/4	0.035	13.5	6.4	14.3	3700(254)
ME86S	1/2	0.049	3/8	0.035	13.5	6.4	14.3	3300(227)

### 公制

产品型号	T-Tube管 外径(mm)	t-壁厚 (mm)	Tx-Tube管 外径(mm)	tx-壁厚 (mm)	尺寸 (mm)			工作压力 psig (bar)
					L	B	F	
ME8M6MS	8	1.0	6	1.0	11.9	6.4	11.1	4499(310)
ME10M6MS	10	1.0	6	1.0	11.9	6.4	11.1	3483(240)
ME12M6MS	12	1.0	6	1.0	13.5	6.4	14.3	2902(200)
ME12M8MS	12	1.0	8	1.0	13.5	6.4	14.3	2902(200)

**MEL**  
微型单端加长90°弯头

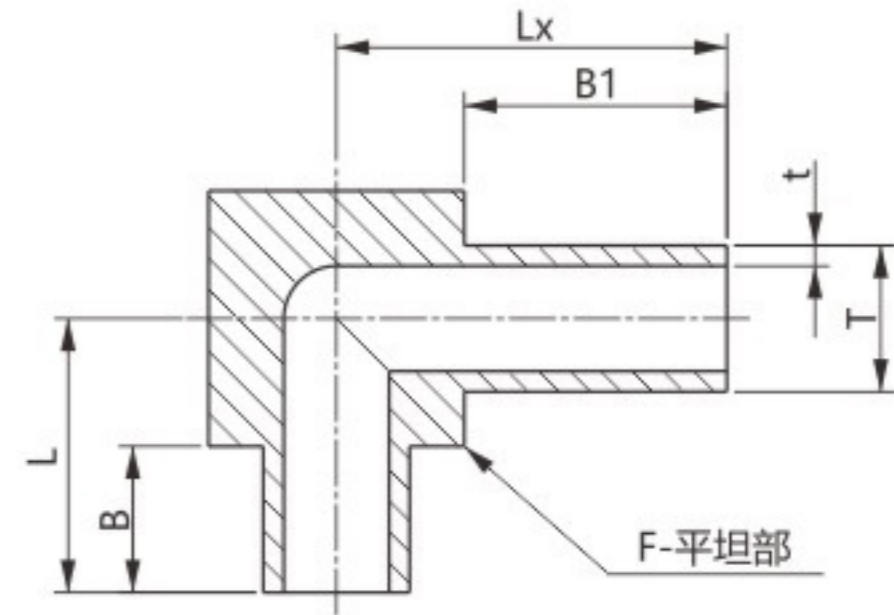
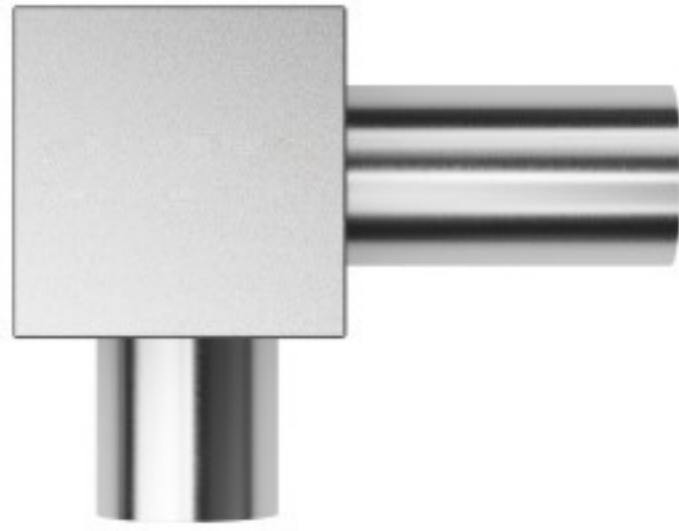

英制

产品型号	T-Tube管 外径(in.)	t-壁厚 (in.)	尺寸 (mm)					工作压力 psig (bar)
			B	B <sub>1</sub>	L	L <sub>x</sub>	F	
MEL4S-1	1/4	0.035	6.4	11.4	10.4	15.5	7.9	5100(351)
MEL4S-2	1/4	0.035	6.4	12.7	10.4	16.8	7.9	5100(351)
MEL4S-3	1/4	0.035	11.4	11.4	15.5	15.5	7.9	5100(351)
MEL4S-4	1/4	0.035	12.7	12.7	16.8	16.8	7.9	5100(351)

**MEF**  
微型45°弯头

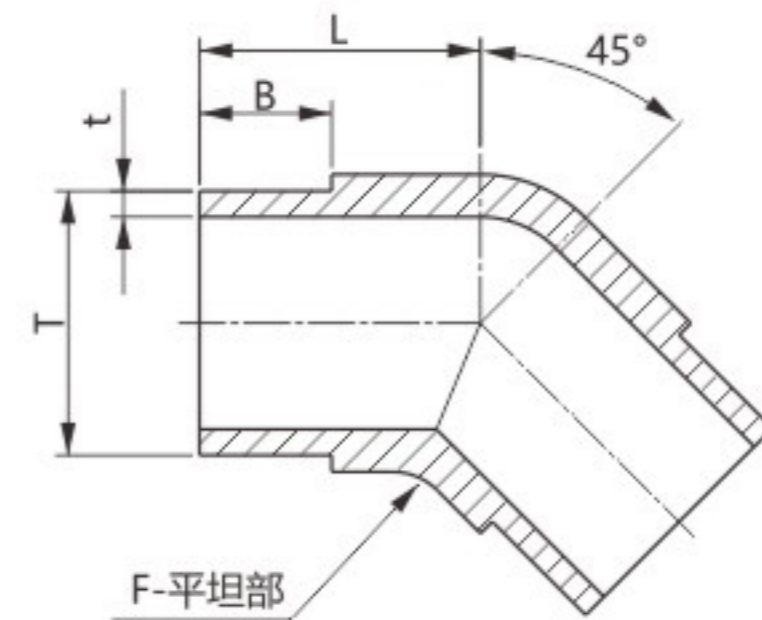
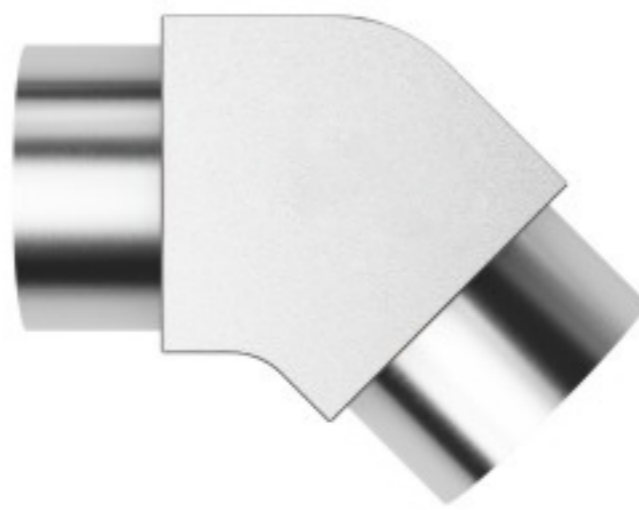

英制

产品型号	T-Tube管 外径(in.)	t-壁厚 (in.)	尺寸 (mm)			工作压力 psig (bar)
			L	B	F	
MEF4S	1/4	0.035	10.4	6.4	7.9	5100(351)
MEF6S	3/8	0.035	11.9	6.4	11.1	3300(227)
MEF8S	1/2	0.049	13.5	6.4	14.3	3700(254)

## MTB 微型三维三通接头

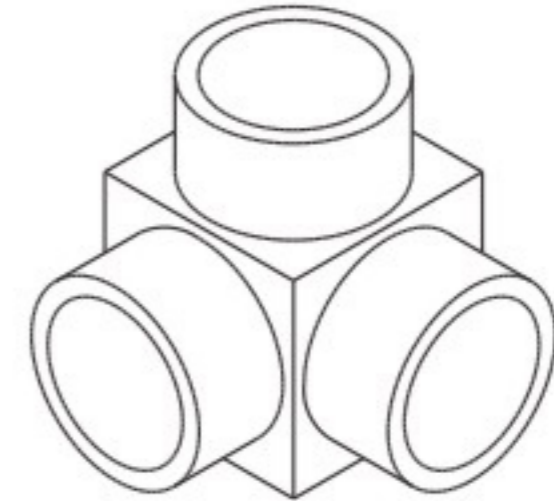
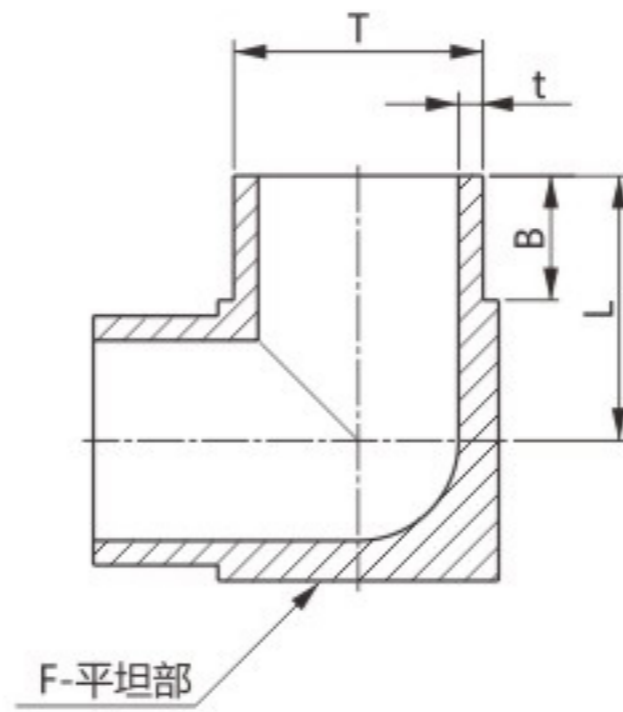
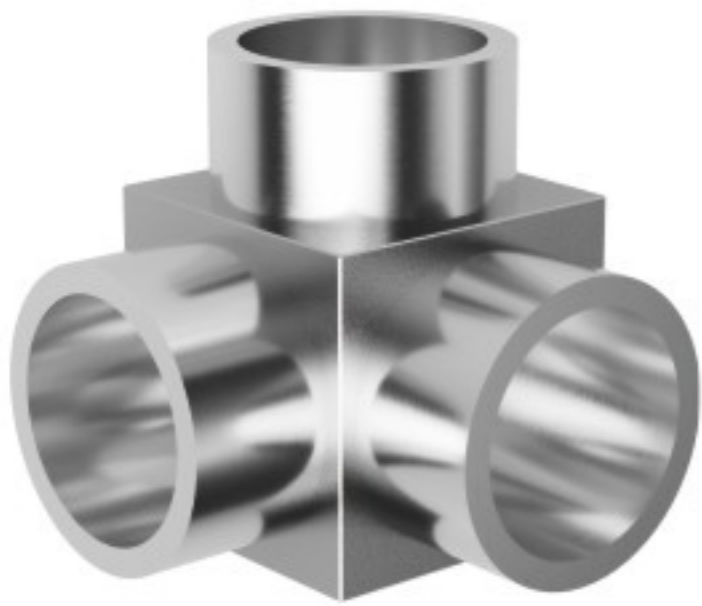

### 英制

产品型号	T-Tube管 外径(in.)	t-壁厚 (in.)	尺寸 (mm)			工作压力 psig (bar)
			L	B	F	
MTB4S	1/4	0.035	10.4	6.4	7.9	5100(351)
MTB6S	3/8	0.035	11.9	6.4	11.1	3300(227)
MTB8S	1/2	0.049	13.5	6.4	14.3	3700(254)

### 公制

产品型号	T-Tube管 外径(mm)	t-壁厚 (mm)	尺寸 (mm)			工作压力 psig (bar)
			L	B	F	
MTB6MS	6	1.0	10.4	6.4	7.9	6095(420)

**MT**  
微型三通接头

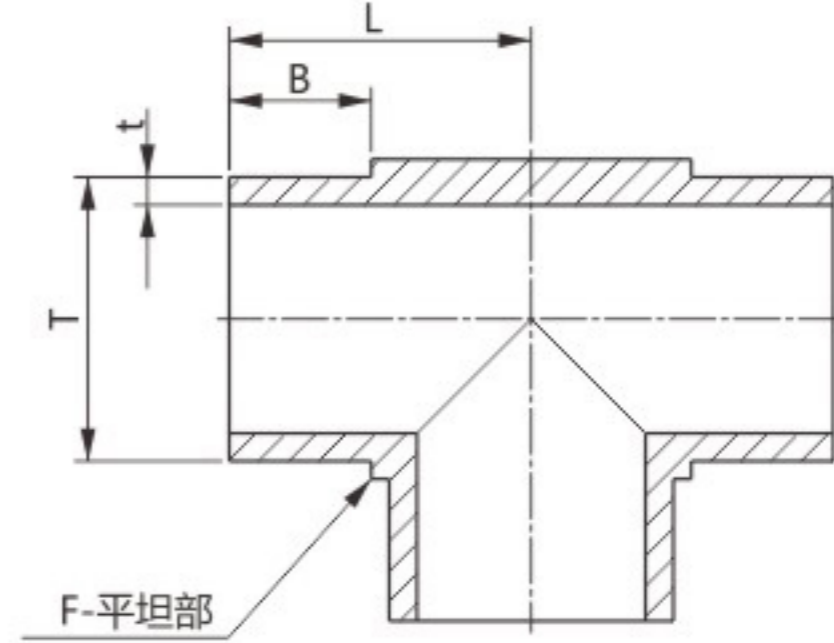

**英制**

产品型号	T-Tube管 外径(in.)	t-壁厚 (in.)	尺寸 (mm)			工作压力 psig (bar)
			L	B	F	
MT2S	1/8	0.028	10.4	6.4	7.9	8500(586)
MT4S	1/4	0.035	10.4	6.4	7.9	5100(351)
MT6S	3/8	0.035	11.9	6.4	11.1	3300(227)
MT8S	1/2	0.049	13.5	6.4	14.3	3700(254)

**公制**

产品型号	T-Tube管 外径(mm)	t-壁厚 (mm)	尺寸 (mm)			工作压力 psig (bar)
			L	B	F	
MT6MS	6	1.0	10.4	6.4	7.9	6095(420)
MT8MS	8	1.0	11.9	6.4	11.1	4499(310)
MT10MS	10	1.0	11.9	6.4	11.1	3483(240)
MT12MS	12	1.0	13.5	6.4	14.3	2902(200)

## MT 微型变径三通接头

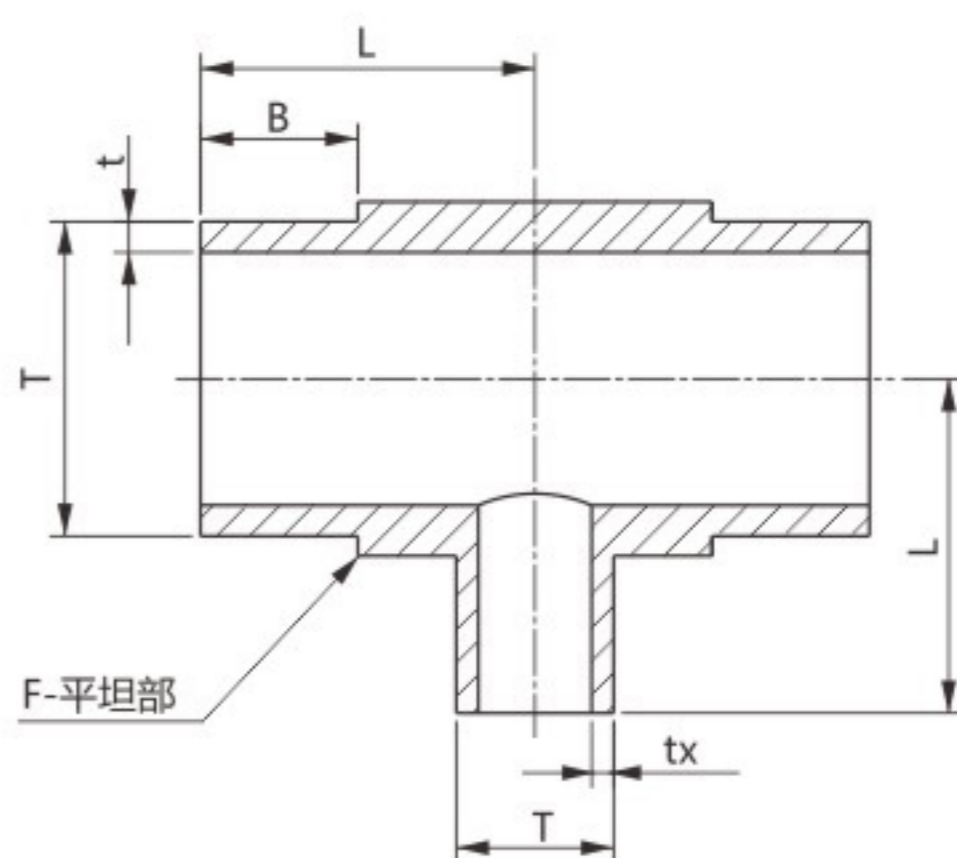
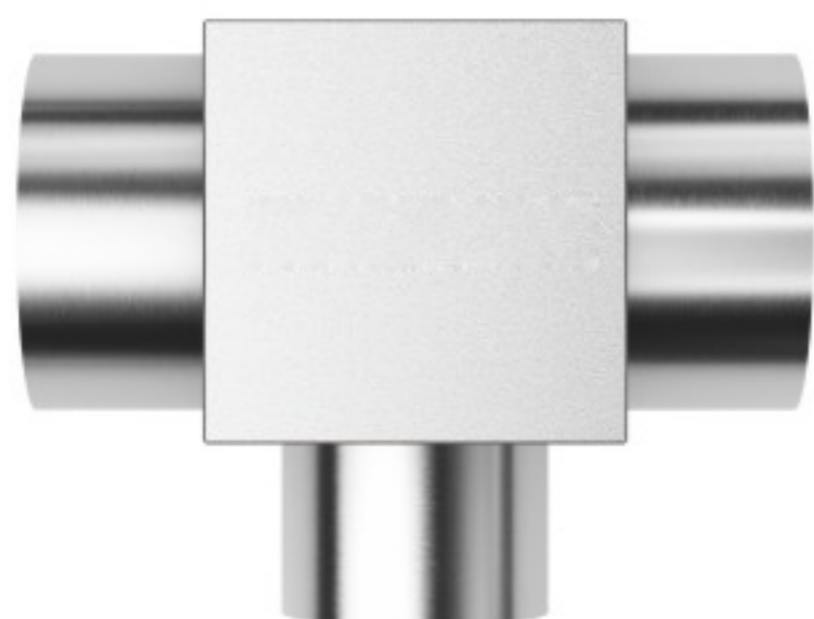

### 英制

产品型号	T-Tube管 外径(in.)	t-壁厚 (in.)	Tx-Tube管 外径(in.)	tx-壁厚 (in.)	尺寸 (mm)			工作压力 psig (bar)
					L	B	F	
MT64S	3/8	0.035	1/4	0.035	11.9	6.4	11.1	3300(227)
MT84S	1/2	0.049	1/4	0.035	13.5	6.4	14.3	3700(254)
MT86S	1/2	0.049	3/8	0.035	13.5	6.4	14.3	3300(227)

### 公制

产品型号	T-Tube管 外径(mm)	t-壁厚 (mm)	Tx-Tube管 外径(mm)	tx-壁厚 (mm)	尺寸 (mm)			工作压力 psig (bar)
					L	B	F	
MT10M6MS	10	1.0	6	1.0	11.9	6.4	11.1	3483(240)
MT12M6MS	12	1.0	6	1.0	13.5	6.4	14.3	2902(200)
MT12M8MS	12	1.0	8	1.0	13.5	6.4	14.3	2902(200)



## MCT 微型四通接头

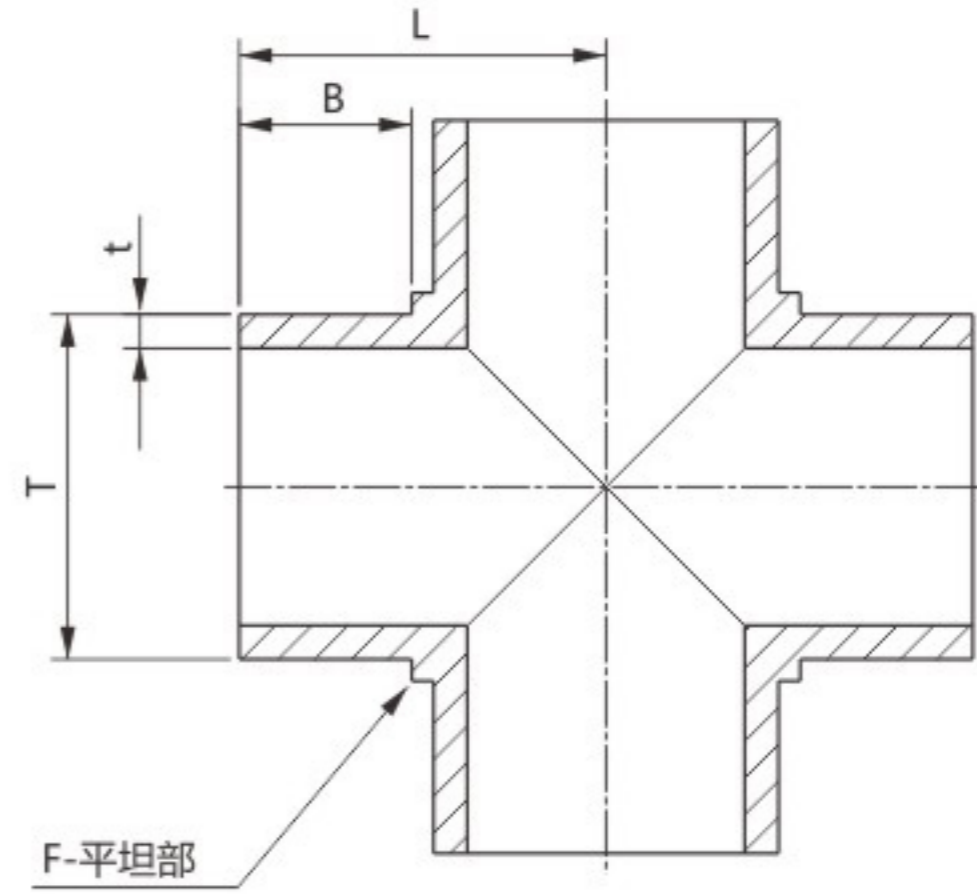
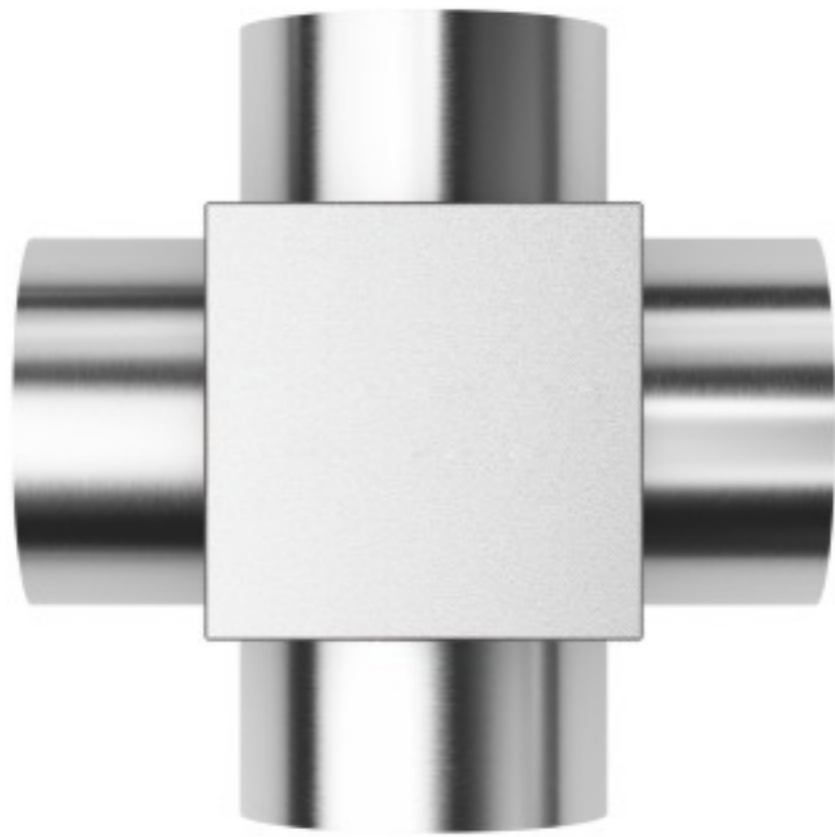

### 英制

产品型号	T-Tube管 外径(in.)	t-壁厚 (in.)	尺寸 (mm)			工作压力 psig (bar)
			L	B	F	
MCT2S	1/8	0.028	10.4	6.4	7.9	8500(586)
MCT4S	1/4	0.035	10.4	6.4	7.9	5100(351)
MCT6S	3/8	0.035	11.9	6.4	11.1	3300(227)
MCT8S	1/2	0.049	13.5	6.4	14.3	3700(254)

### 公制

产品型号	T-Tube管 外径(mm)	t-壁厚 (mm)	尺寸 (mm)			工作压力 psig (bar)
			L	B	F	
MCT6MS	6	1.0	10.4	6.4	7.9	6095(420)
MCT8MS	8	1.0	11.9	6.4	11.1	4499(310)
MCT10MS	10	1.0	11.9	6.4	11.1	3483(240)
MCT12MS	12	1.0	13.5	6.4	14.3	2902(200)

## 高纯加长型焊接接头

### 特征:

加长的Tube管结构设计

尺寸范围: 1/4"至1", 6mm至18mm

除直通结构外, 其他结构的接头均由锻件毛坯加工而成

### LR

#### 变径直通接头

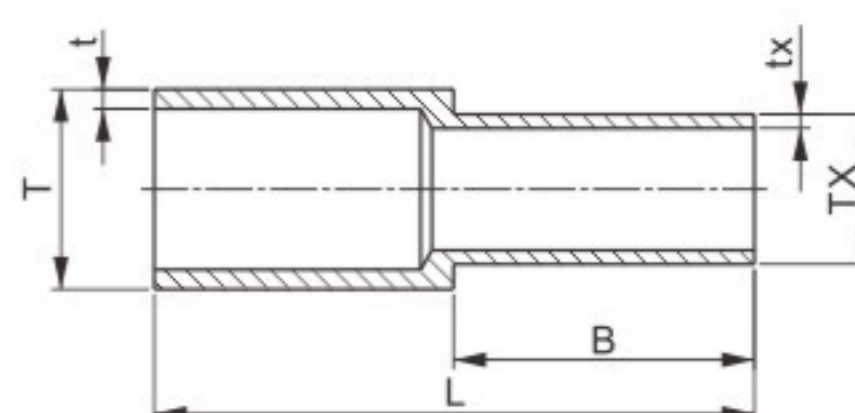
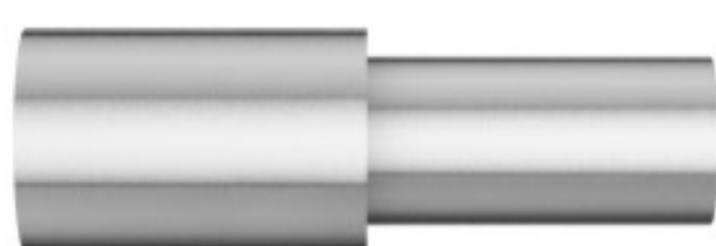

#### 英制

产品型号	T-Tube管 外径(in.)	t-壁厚 (in.)	Tx-Tube管 外径(in.)	tx-壁厚 (in.)	尺寸 (mm)		工作压力 psig (bar)
					L	B	
LR64S	3/8	0.035	1/4	0.035	38.1	19.1	3300(227)
LR84S	1/2	0.049	1/4	0.035	38.1	19.1	3700(254)
LR86S	1/2	0.049	3/8	0.035	38.1	19.1	3300(227)
LR128S	3/4	0.049	1/2	0.049	38.1	19.1	2400(165)
LR168S	1	0.065	1/2	0.049	38.1	19.1	2400(165)
LR1612S	1	0.065	3/4	0.049	38.1	19.1	2400(165)

#### 公制

产品型号	T-Tube管 外径(mm)	t-壁厚 (mm)	Tx-Tube管 外径(mm)	tx-壁厚 (mm)	尺寸 (mm)		工作压力 psig (bar)
					L	B	
LR10M6MS	10	1.0	6	1.0	38.1	19.1	3483 (240)
LR10M8MS	10	1.0	8	1.0	38.1	19.1	3483 (240)
LR12M6MS	12	1.0	6	1.0	38.1	19.1	2902 (200)
LR12M8MS	12	1.0	8	1.0	38.1	19.1	2902 (200)
LR12M10MS	12	1.0	10	1.0	38.1	19.1	2902 (200)
LR18M6MS	18	1.5	6	1.0	38.1	19.1	2902 (200)
LR18M12MS	18	1.5	12	1.0	38.1	19.1	2902 (200)

## LE 90°弯头

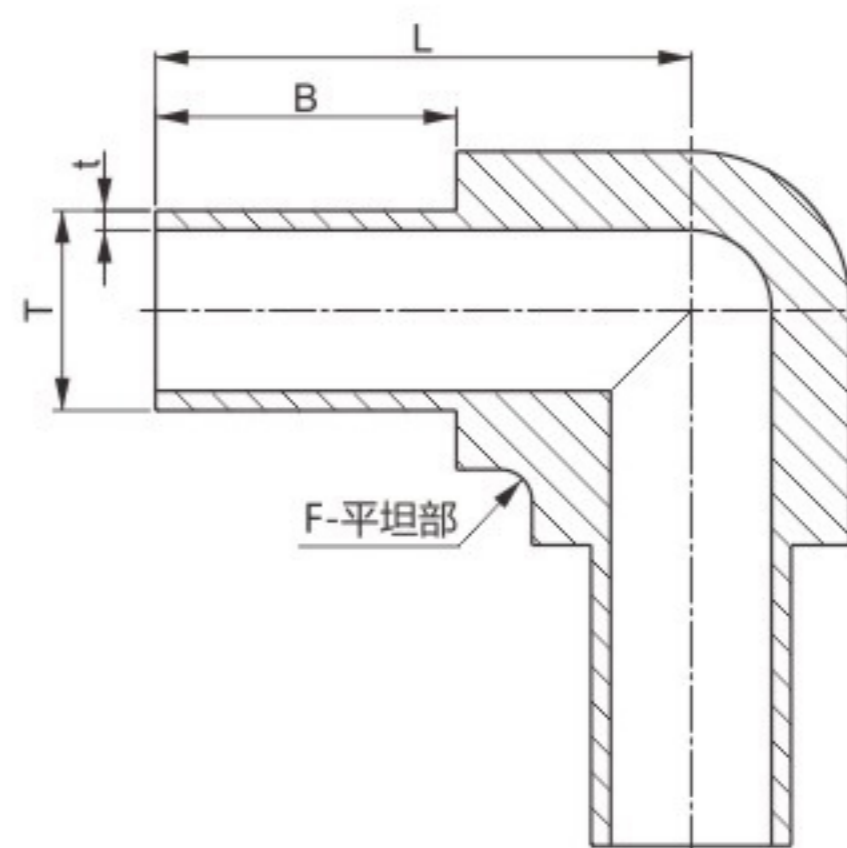

### 英制

产品型号	T-Tube管 外径(in.)	t-壁厚 (in.)	尺寸 (mm)			工作压力 psig (bar)
			L	B	F	
LE4S	1/4	0.035	31.2	19.1	11.1	5100(351)
LE6S	3/8	0.035	30.5	19.1	11.1	3300(227)
LE8S	1/2	0.049	34.0	19.1	17.5	3700(254)
LE12S	3/4	0.049	37.1	19.1	23.8	2400(165)

### 公制

产品型号	T-Tube管 外径(mm)	t-壁厚 (mm)	尺寸 (mm)			工作压力 psig (bar)
			L	B	F	
LE6MS	6	1.0	31.2	19.1	11.1	6092(420)
LE8MS	8	1.0	31.2	19.1	11.1	4499(310)
LE10MS	10	1.0	34.0	19.1	17.5	3483(240)
LE12MS	12	1.0	34.0	19.1	17.5	2902(200)
LE18MS	18	1.5	37.6	19.1	23.8	2902(200)

## LT 三接头

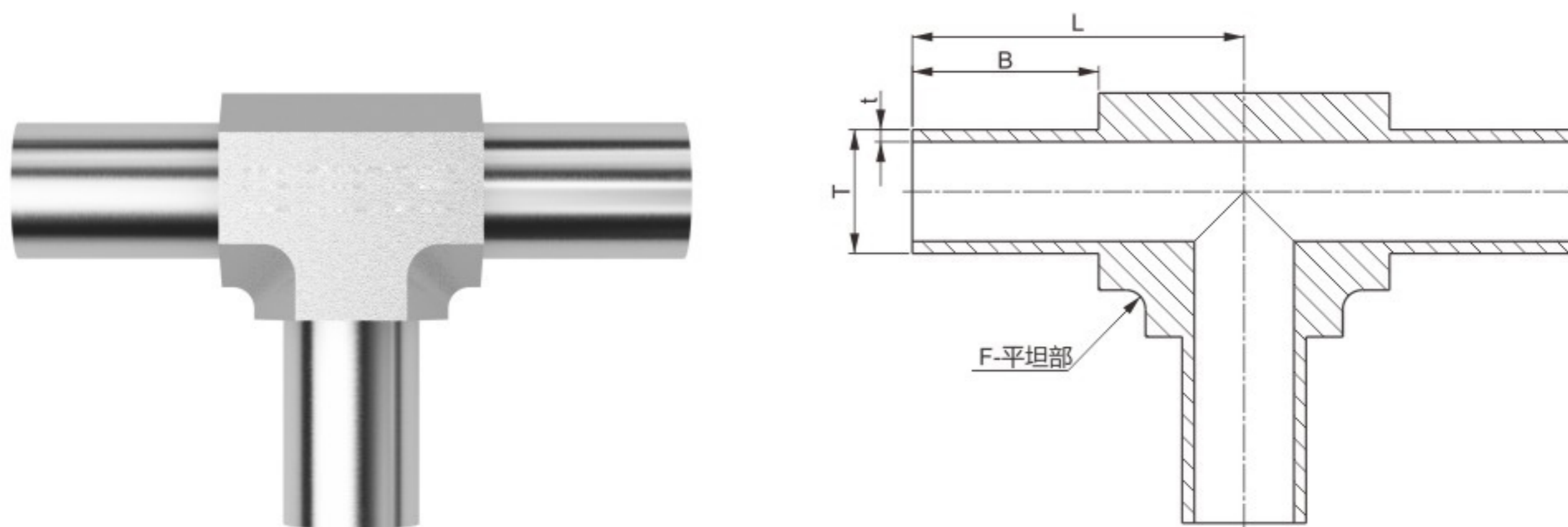

### 英制

产品型号	T-Tube管 外径(in.)	t-壁厚 (in.)	尺寸 (mm)			工作压力 psig (bar)
			L	B	F	
LT4S	1/4	0.035	31.2	19.1	11.1	5100(351)
LT6S	3/8	0.035	30.5	19.1	11.1	3300(227)
LT8S	1/2	0.049	34.0	19.1	17.5	3700(254)
LT12S	3/4	0.049	37.1	19.1	23.8	2400(165)

### 公制

产品型号	T-Tube管 外径(mm)	t-壁厚 (mm)	尺寸 (mm)			工作压力 psig (bar)
			L	B	F	
LT6MS	6	1.0	31.2	19.1	11.1	6092(420)
LT8MS	8	1.0	31.2	19.1	11.1	4499(310)
LT10MS	10	1.0	34.0	19.1	17.5	3483(240)
LT12MS	12	1.0	34.0	19.1	17.5	2902(200)
LT18MS	18	1.5	37.6	19.1	23.8	2902(200)

## LT 变径三通接头

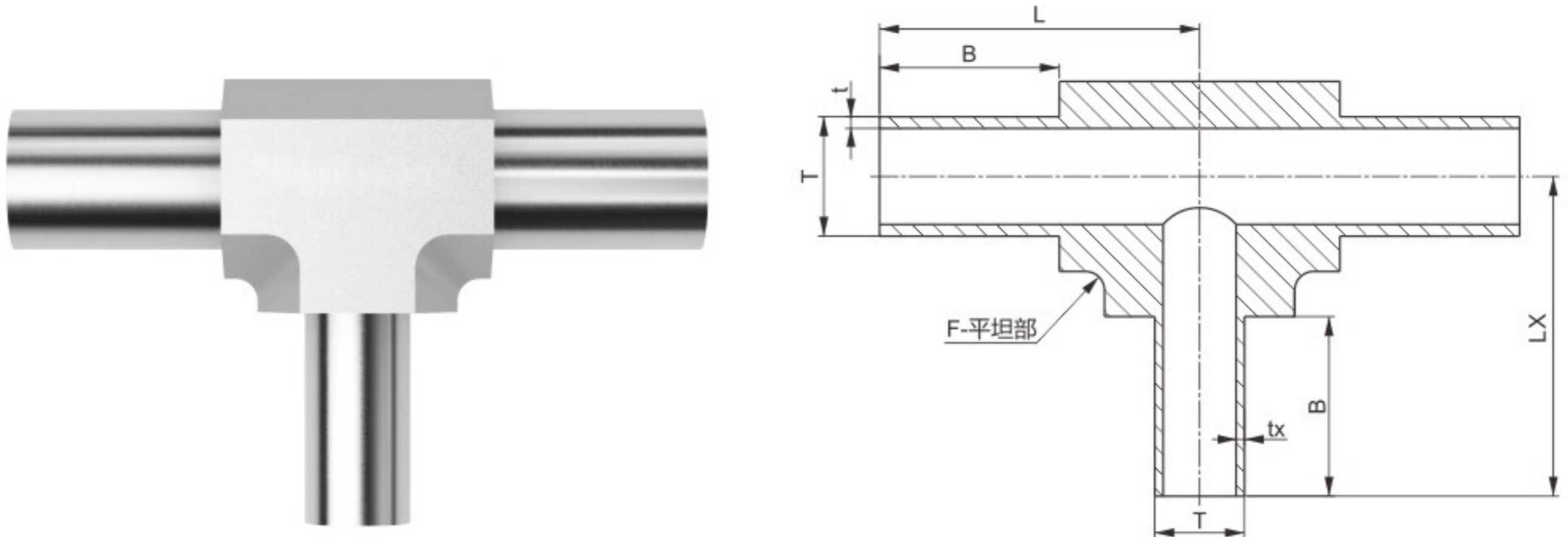

### 英制

产品型号	T-Tube管 外径(in.)	t-壁厚 (in.)	Tx-Tube管 外径(in.)	tx-壁厚 (in.)	尺寸 (mm)				工作压力 psig (bar)
					L	Lx	B	F	
LT64S	3/8	0.035	1/4	0.035	30.5	31.2	19.1	11.1	3300(227)
LT84S	1/2	0.049	1/4	0.035	34.0	34.0	19.1	17.5	3700(254)
LT86S	1/2	0.049	3/8	0.035	34.0	34.3	19.1	17.5	3700(254)
LT124S	3/4	0.049	1/4	0.035	37.1	37.6	19.1	23.8	2400(165)
LT126S	3/4	0.049	3/8	0.035	37.1	34.3	19.1	23.8	2400(165)

### 公制

产品型号	T-Tube管 外径(mm)	t-壁厚 (mm)	Tx-Tube管 外径(mm)	tx-壁厚 (mm)	尺寸 (mm)				工作压力 psig (bar)
					L	Lx	B	F	
LT8M6MS	8	1.0	6	1.0	31.3	31.3	19.1	11.1	4499(310)
LT10M6MS	10	1.0	6	1.0	34.0	34.0	19.1	17.5	3483(240)
LT10M8MS	10	1.0	8	1.0	34.0	34.0	19.1	17.5	3483(240)
LT12M6MS	12	1.0	6	1.0	34.0	34.0	19.1	17.5	2902(200)
LT12M8MS	12	1.0	8	1.0	34.0	34.0	19.1	17.5	2902(200)

## LCT 四通接头

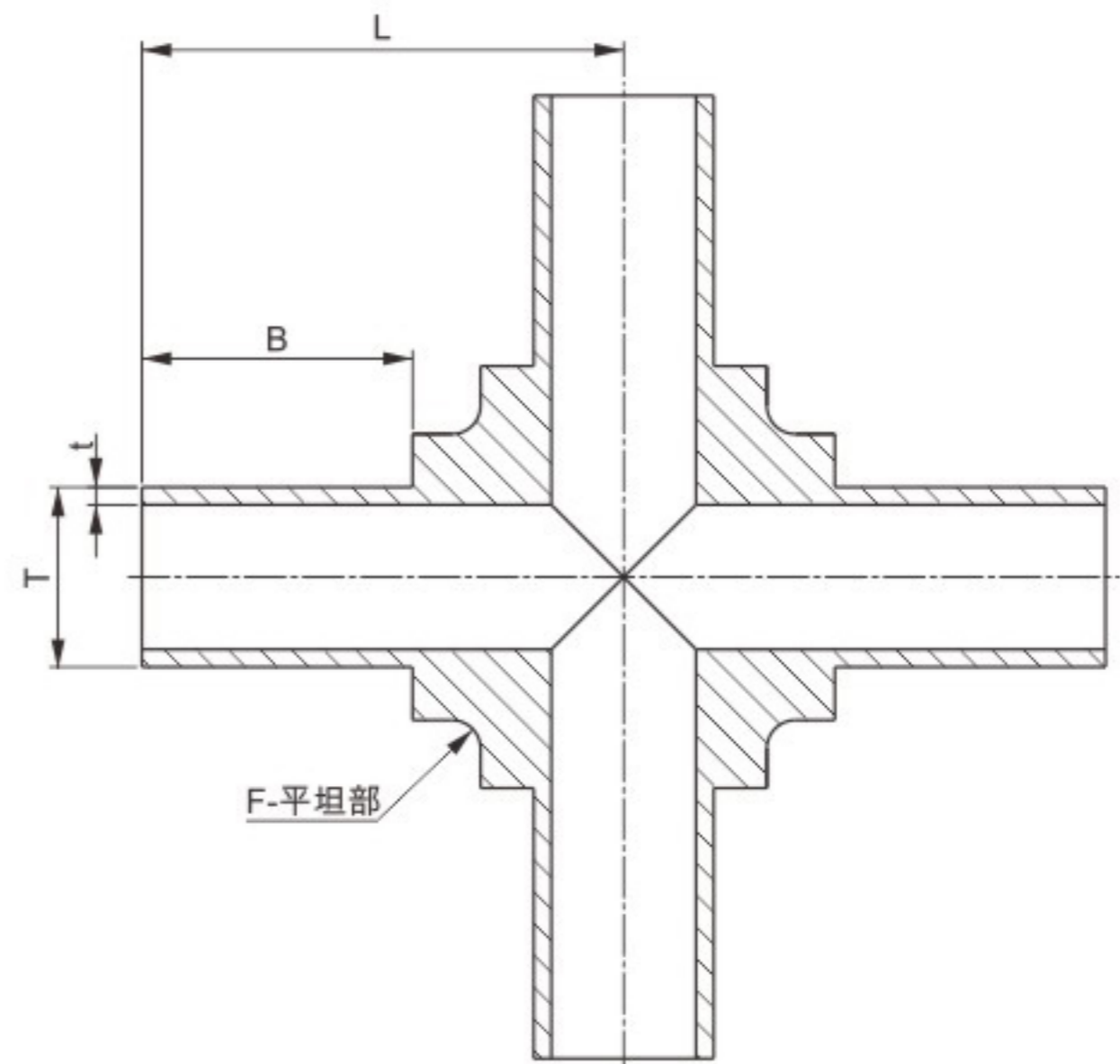

### 英制

产品型号	T-Tube管 外径(in.)	t-壁厚 (in.)	尺寸 (mm)			工作压力 psig (bar)
			L	B	F	
LCT4S	1/4	0.035	31.2	19.1	11.1	5100(351)
LCT6S	3/8	0.035	30.5	19.1	11.1	3300(227)
LCT8S	1/2	0.049	34.0	19.1	17.5	3700(254)

### 公制

产品型号	T-Tube管 外径(mm)	t-壁厚 (mm)	尺寸 (mm)			工作压力 psig (bar)
			L	B	F	
LCT6MS	6	1.0	31.2	19.1	11.1	6092(420)
LCT8MS	8	1.0	31.2	19.1	11.1	4499(310)
LCT10MS	10	1.0	34.0	19.1	15.9	3483(240)
LCT12MS	12	1.0	34.0	19.1	15.9	2902(200)

## VCR 金属垫片面密封接头

### 特征:

金属对金属密封, 在真空到高压范围内提供无泄漏服务  
精密制造的垫片确保最高性能  
螺母端测试孔易于进行泄漏测试  
螺母内螺纹镀银  
流道进行电解抛光, 其表面粗糙度可达Ra 0.25 $\mu$ m(10 $\mu$ in.)  
所有密封面和阳螺纹端都有塑料帽保护  
尺寸范围: 1/8"至1"和6mm至18mm

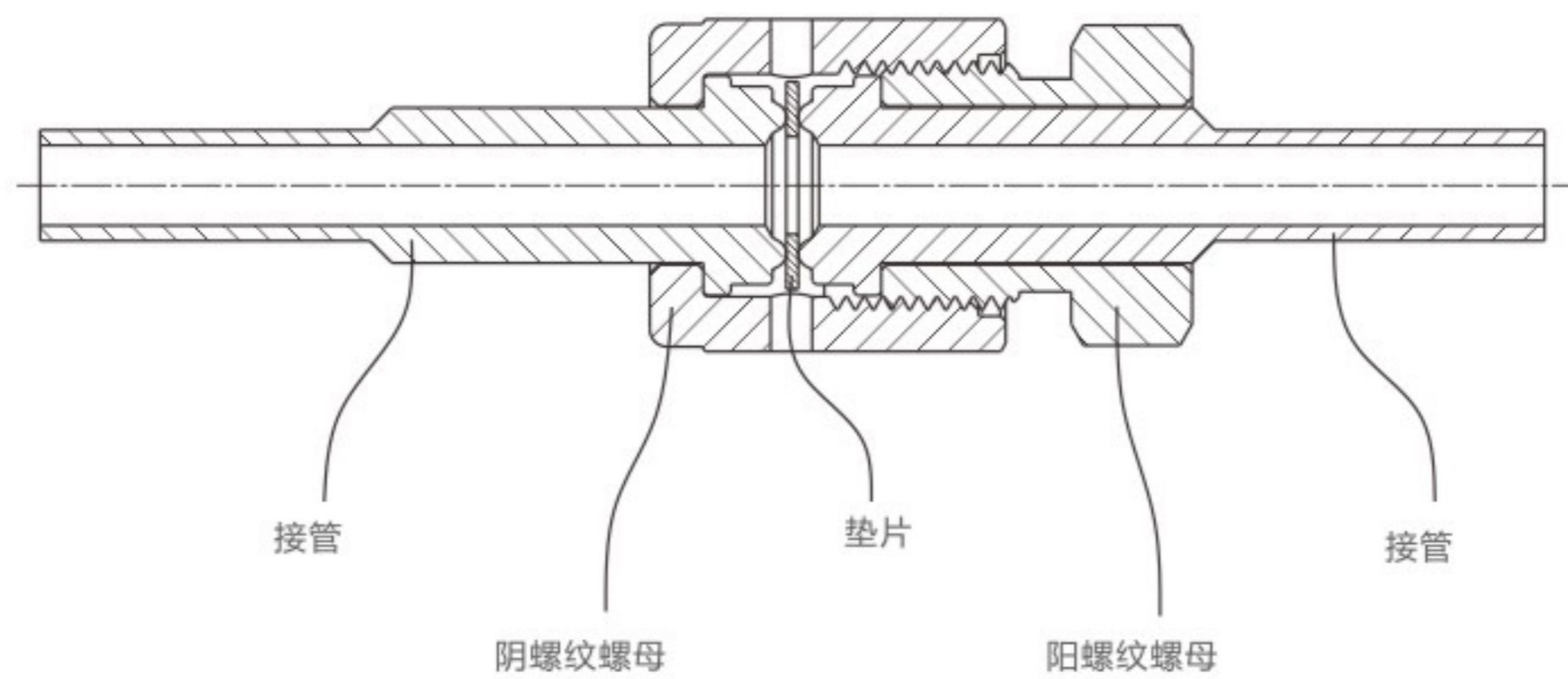

## TSG 短Tube管对焊接管

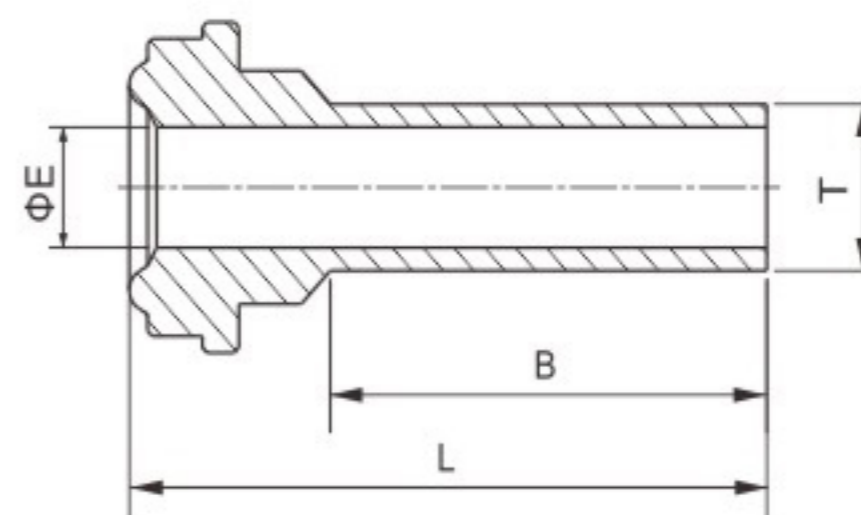
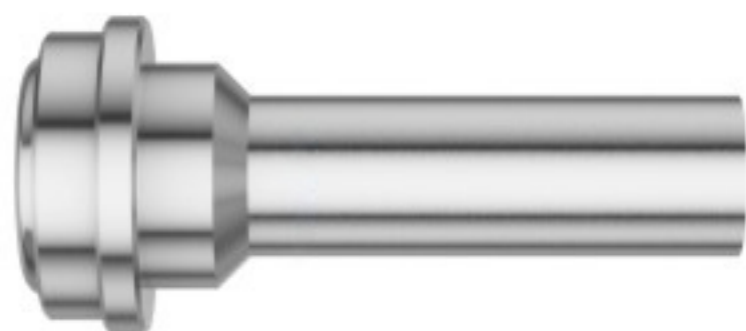

### 英制

产品型号	VCR 尺寸 (in.)	T-Tube管 外径(in.)	常规壁厚 (in.)	尺寸 (mm)			工作压力 psig(bar)	
				L	B	E	6L	NI
TSG22S19	1/8	1/8	0.028	27.4	19.1	1.5	8500(586)	8500(586)
TSG42S19	1/4	1/8	0.028	27.9	19.1	1.5	5100(351)	5100(351)
TSG44S6	1/4	1/4	0.035	15.2	6.4	4.6	5100(351)	5100(351)
TSG44S10	1/4	1/4	0.035	18.3	9.6	4.6	5100(351)	5100(351)
TSG44S19	1/4	1/4	0.035	27.9	19.1	4.6	5100(351)	5100(351)
TSG84S19	1/2	1/4	0.035	28.4	19.1	4.6	4300(296)	3500(241)
TSG86S6	1/2	3/8	0.035	15.7	6.4	7.9	3300(227)	3300(227)
TSG86S19	1/2	3/8	0.035	28.4	19.1	7.9	3300(227)	3300(227)
TSG88S6	1/2	1/2	0.049	15.7	6.4	10.2	3500(241)	3500(241)
TSG88S10	1/2	1/2	0.049	18.8	9.6	10.2	3500(241)	3500(241)
TSG88S19	1/2	1/2	0.049	28.4	19.1	10.2	3500(241)	3500(241)

### 公制

产品型号	VCR 尺寸 (mm)	T-Tube管 外径(mm)	常规壁厚 (mm)	尺寸 (mm)			工作压力 psig(bar)	
				L	B	E	6L	NI
TSG46MS19	1/4	6	1.0	29.5	19.1	4.0	6800(468)	
TSG48MS19	1/4	8	1.0	29.5	19.1	6.0	4900(337)	
TSG810MS19	1/2	10	1.0	29.5	19.1	8.0	3500(241)	
TSG812MS19	1/2	12	1.0	29.5	19.1	10.0	3100(213)	
TSG1218MS19	3/4	18	1.5	31.0	19.1	15.0	3000(206)	



## TLG 长Tube管对焊接管

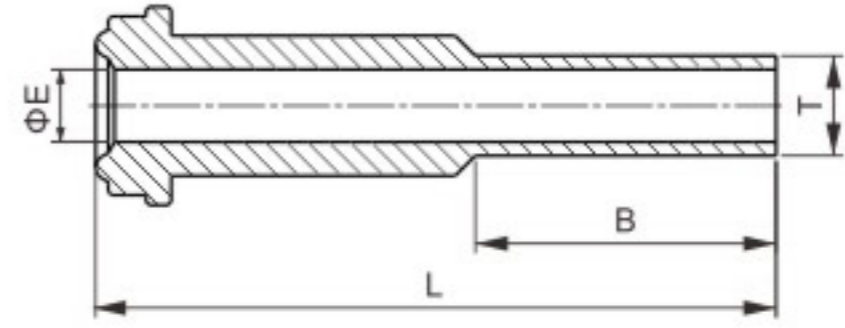
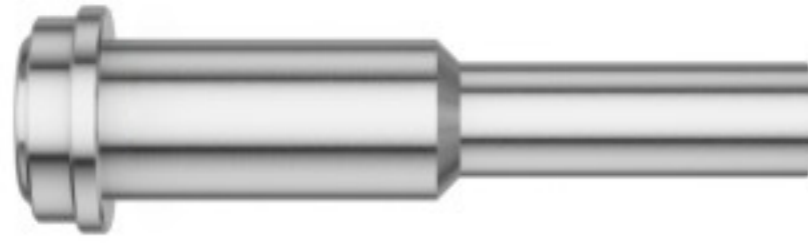

### 英制

产品型号	VCR 尺寸 (in.)	T-Tube管 外径(in.)	常规壁厚 (in.)	尺寸 (mm)			工作压力 psig(bar)	
				L	B	E	6L	NI
TLG22S19	1/8	1/8	0.028	36.1	19.1	1.8	8500(586)	8500(586)
TLG44S6	1/4	1/4	0.035	30.5	6.4	4.6	5100(351)	5100(351)
TLG44S10	1/4	1/4	0.035	33.5	9.6	4.6	5100(351)	5100(351)
TLG44S19	1/4	1/4	0.035	43.2	19.1	4.6	5100(351)	5100(351)
TLG84S19	1/2	1/4	0.035	45.7	19.1	4.6	4300(296)	3500(241)
TLG86S6	1/2	3/8	0.035	32.8	6.4	7.9	3300(227)	3300(227)
TLG86S19	1/2	3/8	0.035	45.5	19.1	7.9	3300(227)	3300(227)
TLG88S6	1/2	1/2	0.049	32.8	6.4	10.2	3500(241)	3500(241)
TLG88S10	1/2	1/2	0.049	35.8	9.6	10.2	3500(241)	3500(241)
TLG88S19	1/2	1/2	0.049	45.5	19.1	10.2	3500(241)	3500(241)
TLG1212S19	3/4	3/4	0.049	51.6	19.1	16.5	2400(165)	2400(165)
TLG1616S19	1	1	0.065	58.9	19.1	22.1	2400(165)	2400(165)

### 公制

产品型号	VCR 尺寸 (mm)	T-Tube管 外径(mm)	常规壁厚 (mm)	尺寸 (mm)			工作压力 psig(bar)	
				L	B	E	6L	NI
TSG46MS19	1/4	6	1.0	43.2	19.1	4.0	6800(468)	
TSG48MS19	1/4	8	1.0	43.2	19.1	6.0	4900(337)	
TSG810MS19	1/2	10	1.0	45.5	19.1	8.0	3500(241)	
TSG812MS19	1/2	12	1.0	45.5	19.1	10.0	3100(213)	
TSG1218MS19	3/4	18	1.5	51.6	19.1	15.0	3000(206)	

## TMG Tube管外焊接管

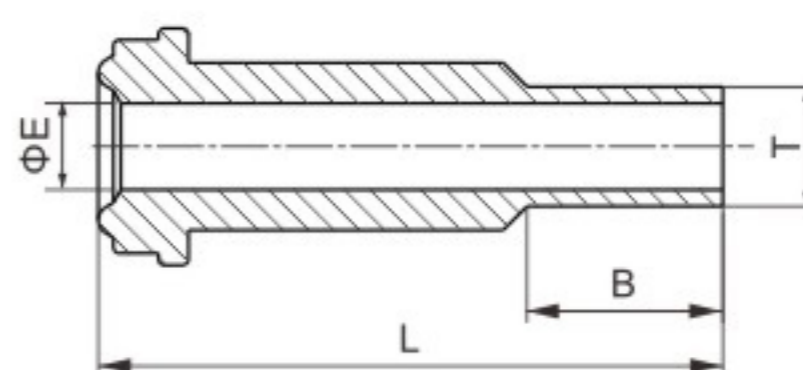
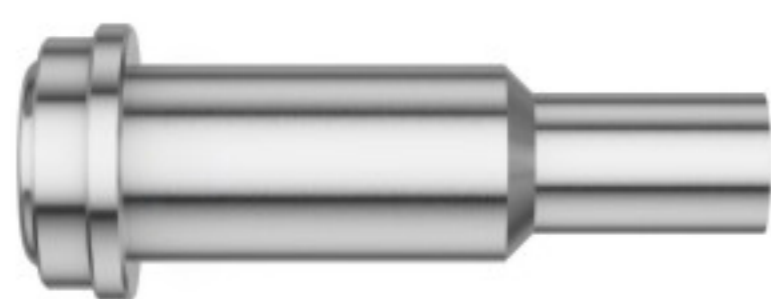

### 英制

产品型号	VCR 尺寸 (in.)	T-Tube管 外径(in.)	尺寸 (mm)			工作压力 psig(bar)	
			L	B	E	6L	NI
TMG22S	1/8	1/8	17.8	7.1	1.8	11200(772)	9000(620)
TMG42S	1/4	1/8	33.3	7.1	1.8	10000(690)	8000(551)
TMG44S	1/4	1/4	33.3	10.4	3.0	10000(690)	8000(551)
TMG84S	1/2	1/4	38.1	10.4	3.0	4300(296)	3500(241)
TMG86S	1/2	3/8	38.1	10.4	7.1	4300(296)	3500(241)
TMG88S	1/2	1/2	38.1	12.7	10.2	3500(241)	3500(241)
TMG1212S	3/4	3/4	50.8	15.7	13.5	3700(254)	3000(206)
TMG1616S	1	1	56.4	20.6	19.1	3000(206)	2400(165)

## TTA 卡套管接管

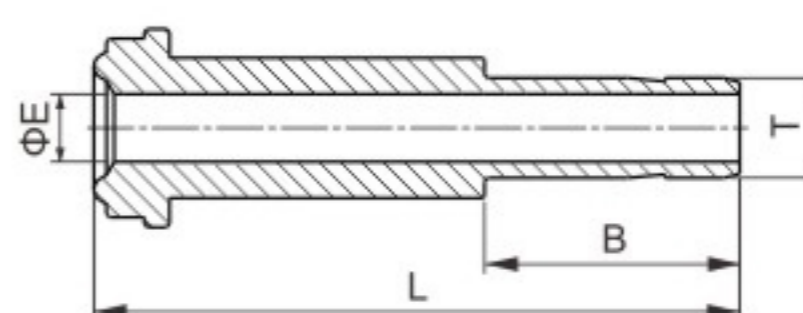
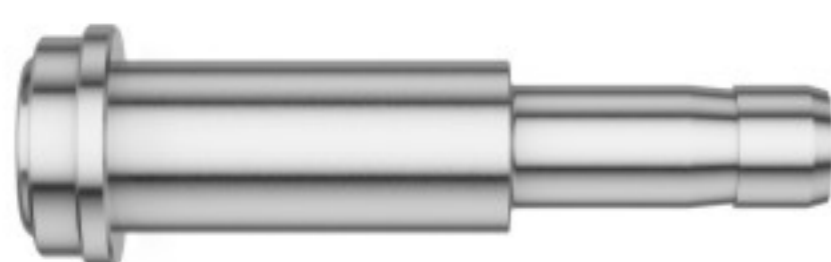

### 英制

产品型号	VCR 尺寸 (in.)	T-Tube管 外径(in.)	尺寸 (mm)			工作压力 psig(bar)	
			L	B	E	6L	NI
TTA44S	1/4	1/4	41.0	16.2	4.3	10000(690)	8000(551)
TTA86S	1/2	3/8	46.0	17.8	6.8	4300(296)	3500(241)
TTA88S	1/2	1/2	49.3	24.4	9.4	4300(296)	3500(241)

**TMCN**  
NPT阳螺纹接头

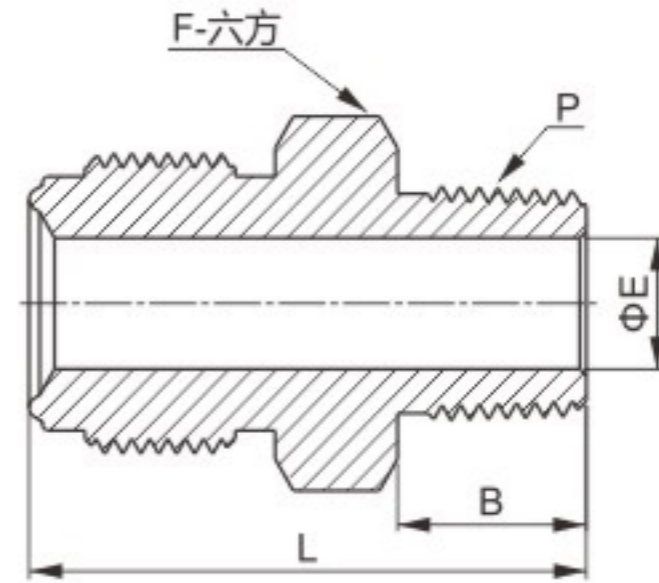

产品型号	VCR 尺寸 (in.)	P-NPT 螺纹规格	尺寸 (mm)				工作压力 psig(bar)	
			L	B	E	F	6L	NI
TMCN21S	1/8	1/16	27.2	9.7	2.3	9.5	9000(620)	9000(620)
TMCN22S	1/8	1/8	27.2	9.7	2.3	11.1	9000(620)	9000(620)
TMCN42S	1/4	1/8	33.3	9.7	4.6	15.9	10000(690)	8000(551)
TMCN44S	1/4	1/4	37.8	14.2	4.6	15.9	10000(690)	8000(551)
TMCN84S	1/2	1/4	41.9	14.2	7.1	23.8	4300(296)	3500(241)
TMCN86S	1/2	3/8	41.9	14.2	9.7	23.8	4300(296)	3500(241)
TMCN88S	1/2	1/2	46.7	19.1	10.2	23.8	4300(296)	3500(241)
TMCN1212S	3/4	3/4	55.6	19.1	15.7	33.3	3700(254)	3000(206)
TMCN1616S	1	1	62.7	23.9	22.1	41.3	3000(206)	3000(206)

## TFCN NPT阴螺纹接头

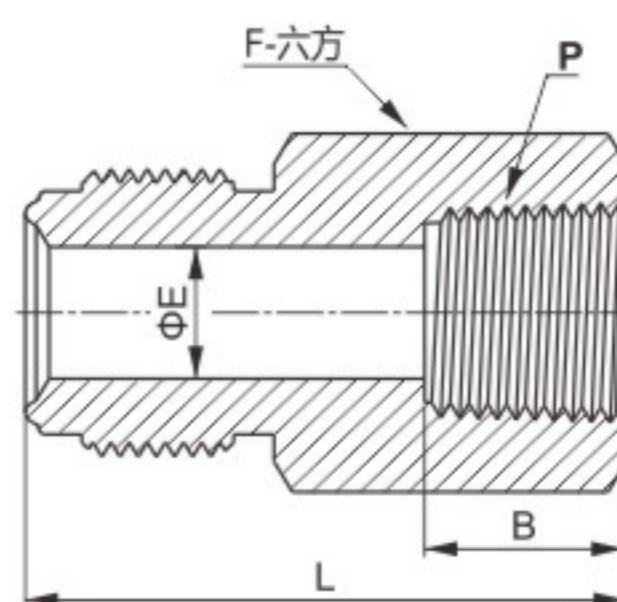
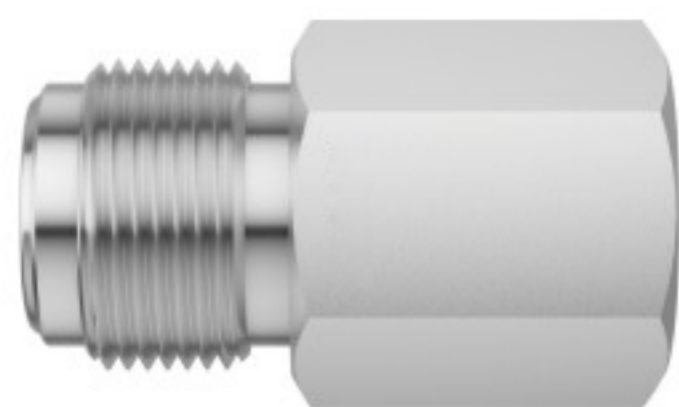

产品型号	VCR 尺寸 (in.)	P-NPT 螺纹规格	尺寸 (mm)				工作压力 psig(bar)	
			L	B	E	F	6L	NI
TFCN21S	1/8	1/16	27.9	9.9	2.3	11.1	6700(461)	6700(461)
TFCN22S	1/8	1/8	30.2	10.4	2.3	14.3	6500(447)	6500(447)
TFCN42S	1/4	1/8	35.8	10.4	4.6	15.9	8000(551)	8000(551)
TFCN44S	1/4	1/4	39.1	15.0	4.6	19.1	6600(454)	6600(454)
TFCN86S	1/2	3/8	44.7	15.0	10.2	23.8	4300(296)	3500(241)
TFCN88S	1/2	1/2	50.5	19.8	10.2	27.0	4300(296)	3500(241)
TFCN1212S	3/4	3/4	59.9	20.6	15.7	33.3	3700(254)	3000(206)
TFCN1616S	1	1	63.8	25.4	22.1	41.3	3000(206)	2400(165)

## TTFC 卡套接头

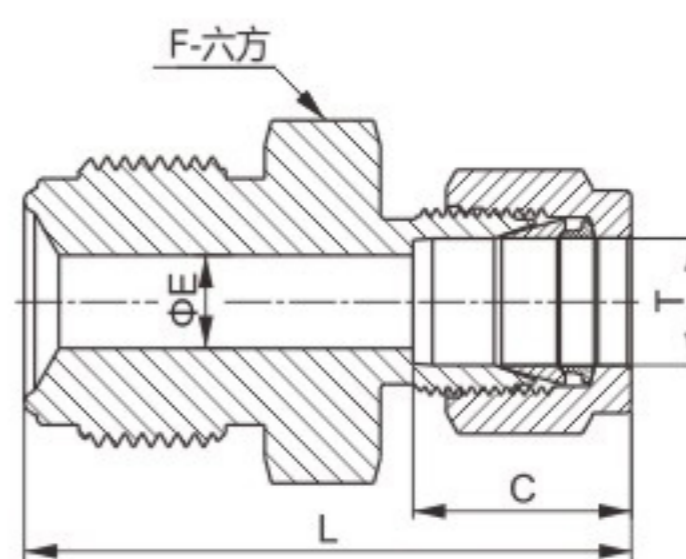
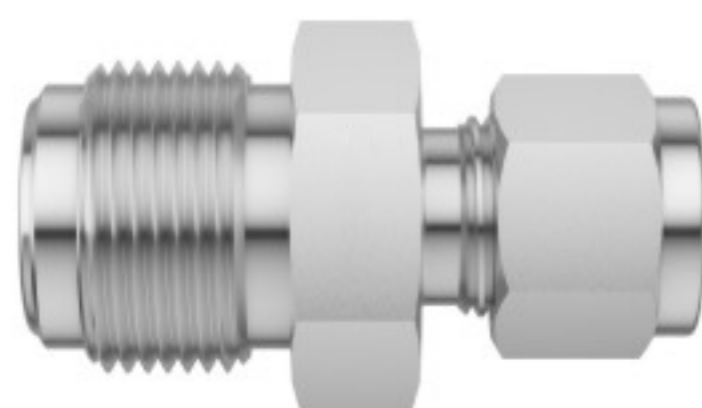

英制

产品型号	VCR 尺寸 (in.)	T-Tube管 外径(in.)	尺寸 (mm)				工作压力 psig(bar)	
			L	C	E	F	6L	NI
TTFC42S	1/4	1/8	38.9	12.7	2.3	15.9	10000(690)	8000(551)
TTFC44S	1/4	1/4	41.1	15.2	4.6	15.9	10000(690)	8000(551)
TTFC86S	1/2	3/8	46.7	16.8	7.1	23.8	4300(296)	3500(241)
TTFC88S	1/2	1/2	49.5	22.9	10.2	23.8	4300(296)	3500(241)

**TTBU**  
卡套穿板接头

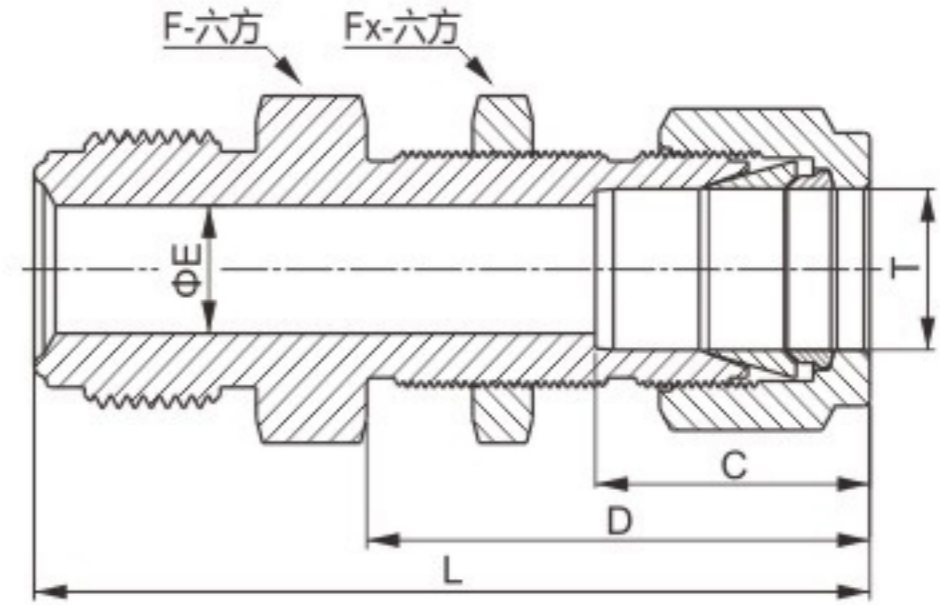
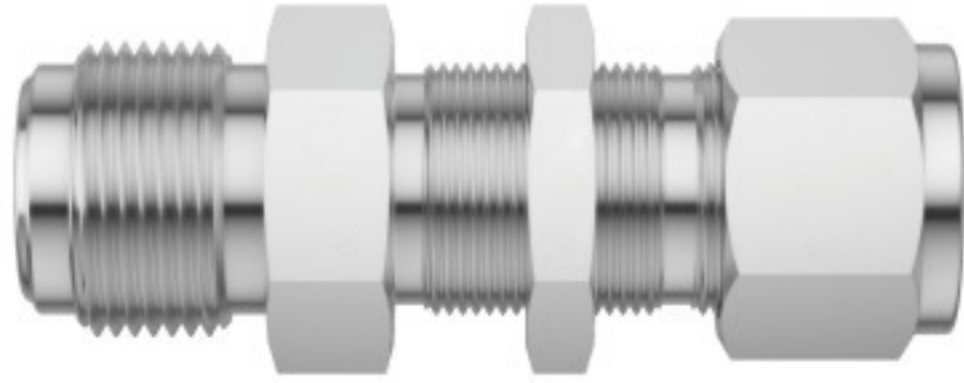

英制

产品型号	VCR 尺寸 (in.)	T-Tube管 外径(in.)	尺寸 (mm)						面板孔径 (mm)	最大面板 厚度(mm)	工作压力 psig(bar)	
			L	C	D	E	F	Fx			6L	NI
TTBU44S	1/4	1/4	57.2	15.2	33.5	4.6	15.9	15.9	11.9	10.2	10000(690)	8000(551)
TTBU86S	1/2	3/8	64.5	16.8	36.8	7.1	23.8	19.1	15.0	11.2	4300(296)	3500(241)
TTBU88S	1/2	1/2	69.6	22.9	41.9	10.2	23.8	23.8	19.8	12.7	4300(296)	3500(241)

**TMU**  
直通接头

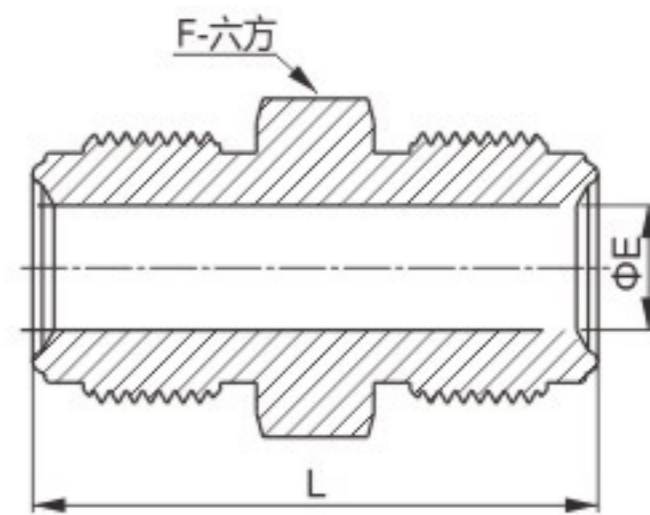
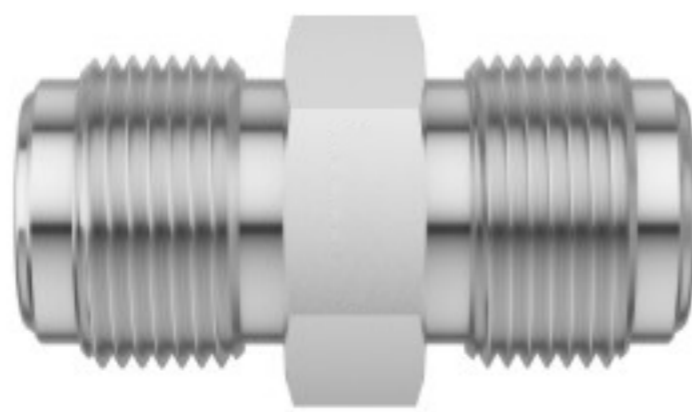

产品型号	VCR 尺寸 (in.)	尺寸 (mm)			工作压力 psig(bar)	
		L	E	F	6L	NI
TMU2S	1/8	28.7	2.3	9.5	11200(772)	9000(620)
TMU4S	1/4	39.4	4.6	15.9	10000(690)	8000(551)
TMU8S	1/2	46.7	10.2	23.8	4300(296)	3500(241)
TMU12S	3/4	62.0	15.7	33.3	3700(254)	3000(206)
TMU16S	1	65.8	22.1	41.3	3000(206)	2400(165)

## TMU 变径直通接头

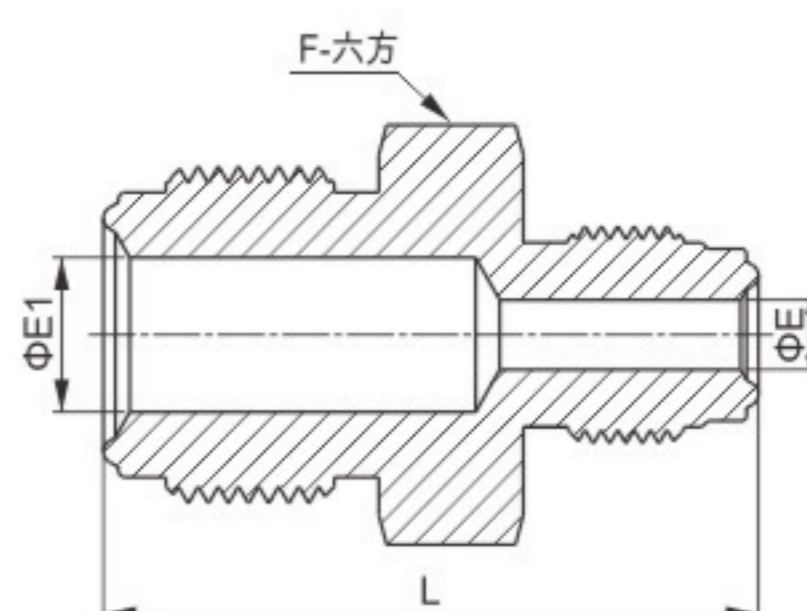
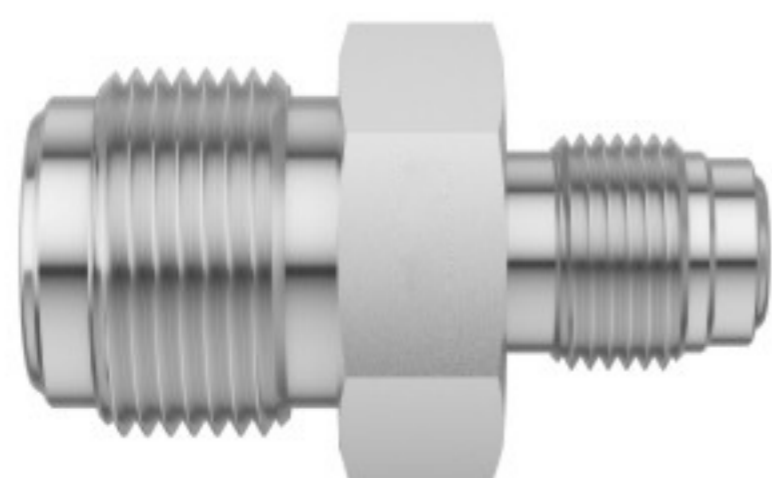

产品型号	VCR 尺寸 (in.)	T-Tube管 外径(in.)	尺寸 (mm)				工作压力 psig(bar)	
			L	E	E1	F	6L	NI
TMU42S	1/4	1/8	34.8	2.3	4.6	15.9	10000(690)	8000(551)
TMU84S	1/2	1/4	43.4	4.6	10.2	23.8	4300(296)	3500(241)

## TBU 穿板直通接头

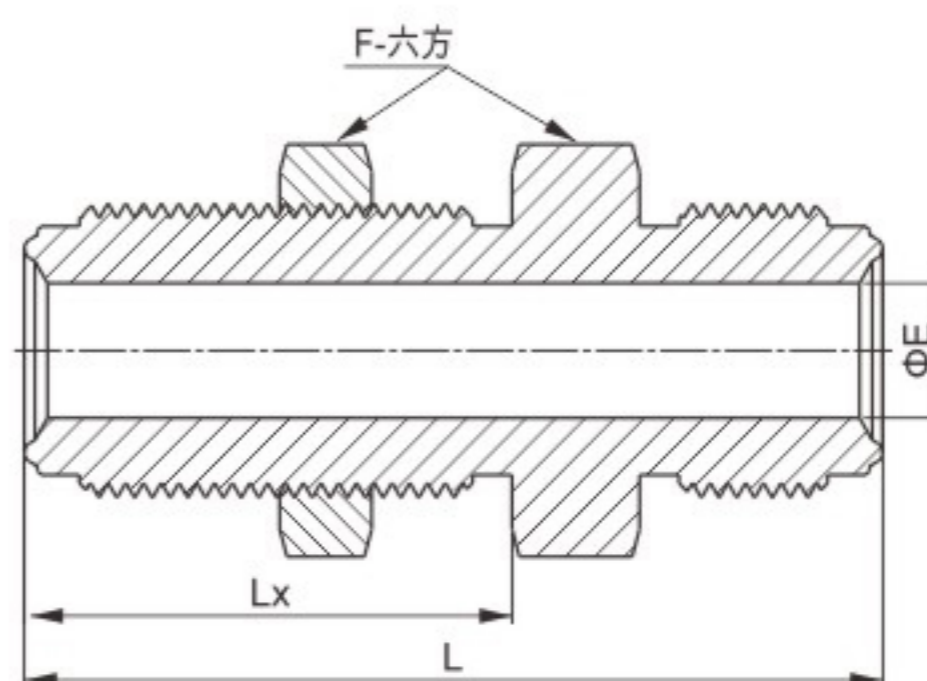
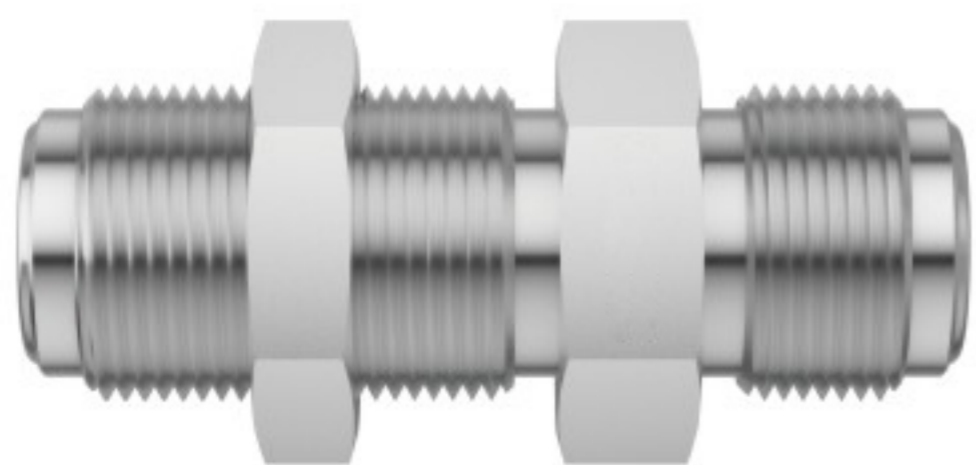

产品型号	VCR 尺寸 (in.)	尺寸 (mm)				面板孔径 (mm)	最大面板 厚度(mm)	工作压力 psig(bar)	
		L	Lx	E	F			6L	NI
TBU4S	1/4	56.6	33.3	4.6	19.1	15.0	11.2	10000(690)	8000(551)
TBU8S	1/2	65.3	37.6	10.2	27.0	23.1	12.7	4300(296)	3500(241)

## TTB Tube管对焊接头

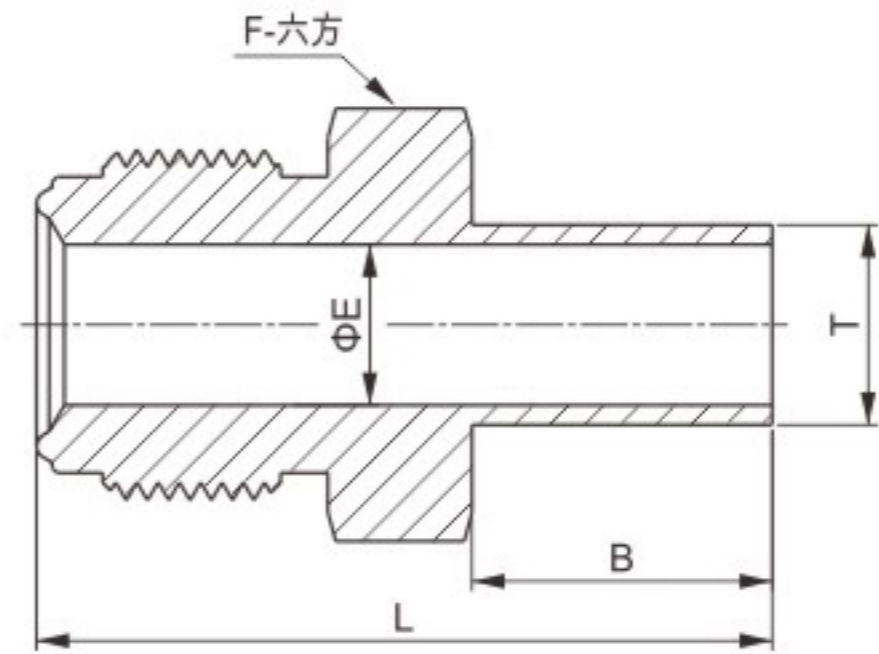
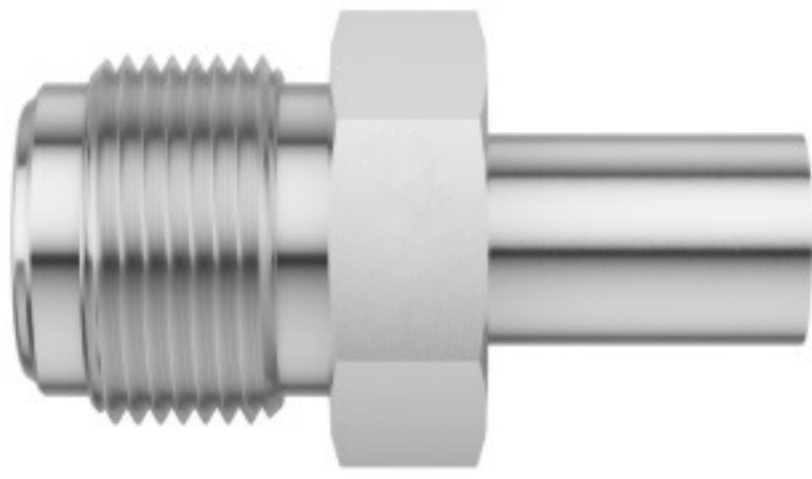

英制

产品型号	VCR 尺寸 (in.)	T-Tube管 外径(in.)	尺寸 (mm)				工作压力 psig(bar)	
			L	B	E	F	6L	NI
TTB44S	1/4	1/4	42.7	19.1	4.6	15.9	10000(690)	8000(551)
TTB86S	1/2	3/8	46.7	19.1	7.7	23.8	4300(296)	3500(241)
TTB88S	1/2	1/2	46.7	19.1	10.2	23.8	3500(241)	3500(241)
TTB1212S	3/4	3/4	55.6	19.1	15.8	33.3	3700(254)	3000(206)

## TTBC 穿板Tube管对焊接头

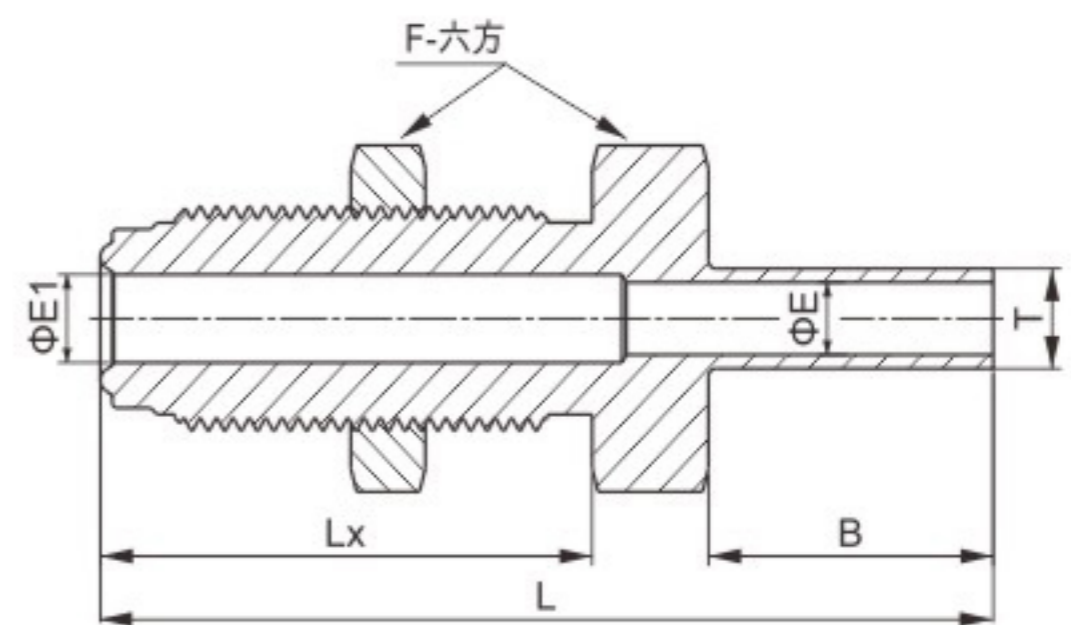
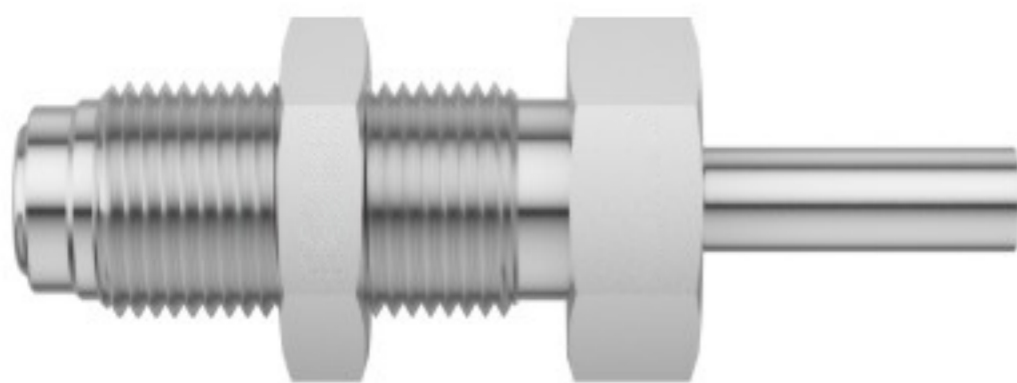

英制

产品型号	VCR 尺寸 (in.)	T-Tube管 外径(in.)	尺寸 (mm)						面板孔径 (mm)	最大面板 厚度(mm)	工作压力 psig(bar)	
			L	Lx	B	E	E1	F			6L	NI
TTBC44S-1.95	1/4	1/4	49.5	25.1	19.1	4.6	5.6	19.1	15.1	3.3	5100(351)	5100(351)
TTBC44S	1/4	1/4	59.9	33.0	19.1	4.6	5.6	19.1	15.1	11.2	5100(351)	5100(351)

**TMEN**  
NPT阳螺纹弯头

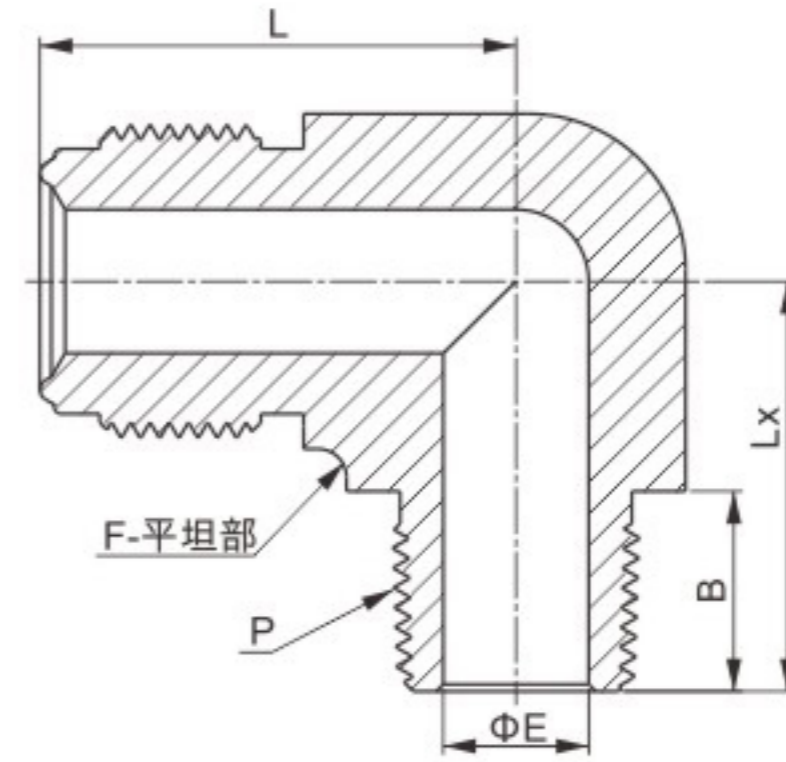
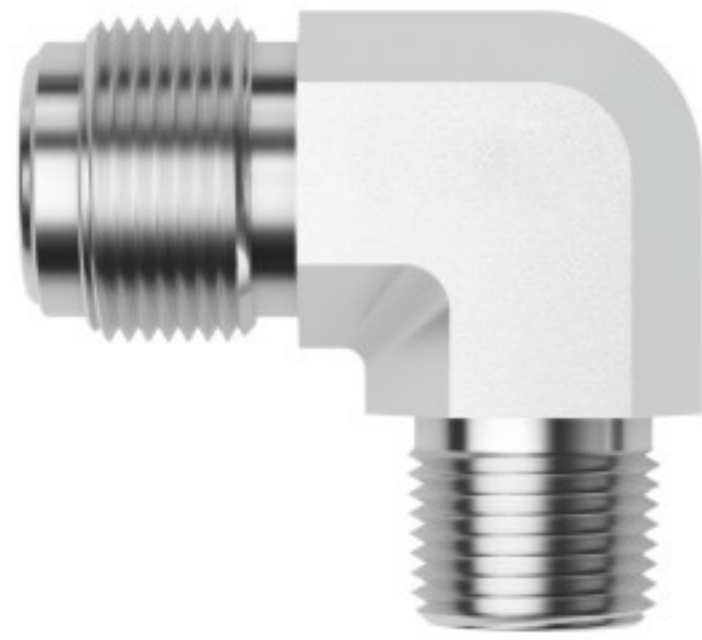

产品型号	VCR 尺寸 (in.)	P-NPT 螺纹规格	尺寸 (mm)					工作压力 psig(bar)	
			L	Lx	B	E	F	6L	NI
TMEN42S	1/4	1/8	27.2	22.1	9.6	4.6	12.7	10000(690)	8000(551)
TMEN44S	1/4	1/4	27.2	26.7	14.2	4.6	12.7	8000(551)	8000(551)
TMEN86S	1/2	3/8	36.8	32.0	14.2	10.2	20.6	4300(296)	3500(241)
TMEN88S	1/2	1/2	36.8	36.8	19.1	10.2	20.9	4300(296)	3500(241)



**TUE**  
90°弯头

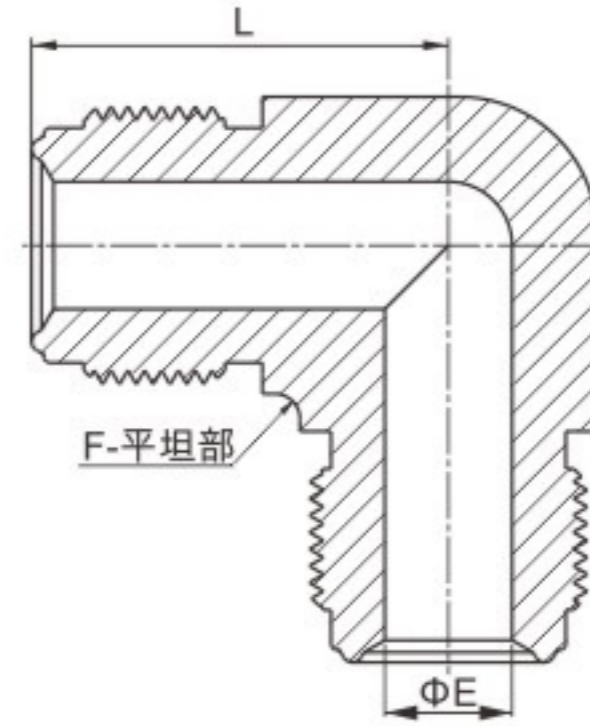
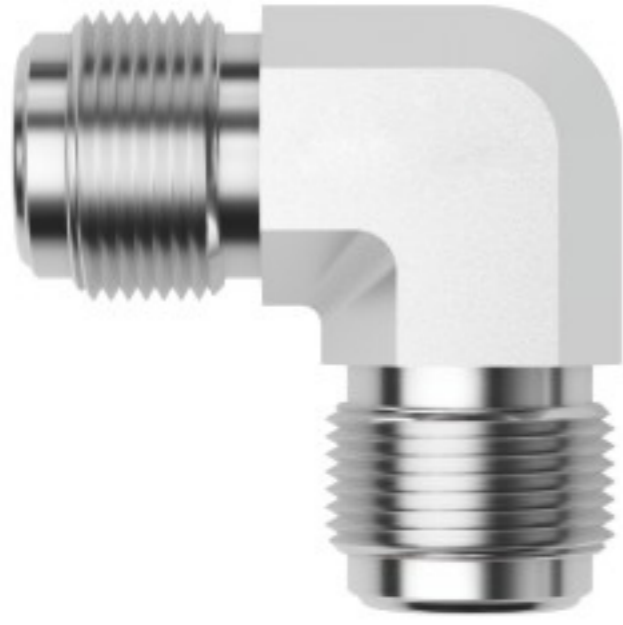

产品型号	VCR 尺寸 (in.)	尺寸 (mm)			工作压力 psig(bar)	
		L	E	F	6L	NI
TUE2S	1/8	22.6	2.3	11.1	11200(772)	9000(620)
TUE4S	1/4	27.2	4.6	12.7	10000(690)	8000(551)
TUE8S	1/2	36.8	10.2	20.6	4300(296)	3500(241)
TUE12S	3/4	48.8	15.7	31.8	3700(254)	3000(206)
TUE16S	1	50.8	22.1	42.9	3000(206)	2400(165)

**TUT**  
三通接头

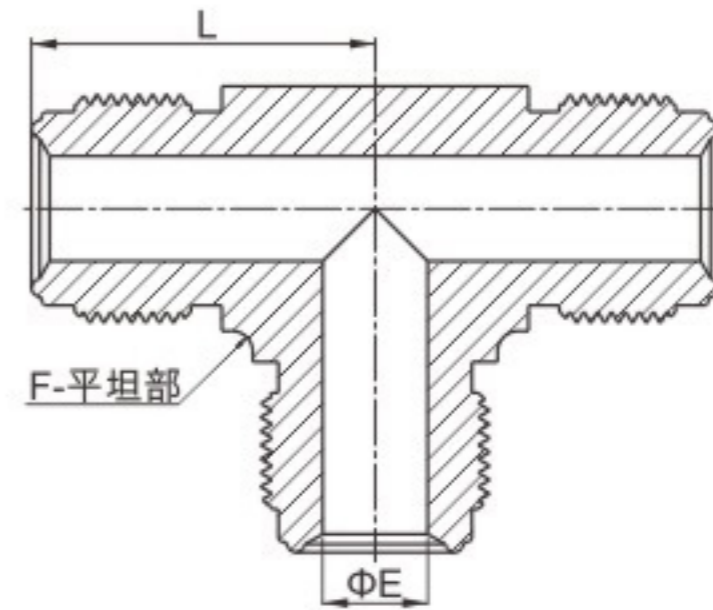
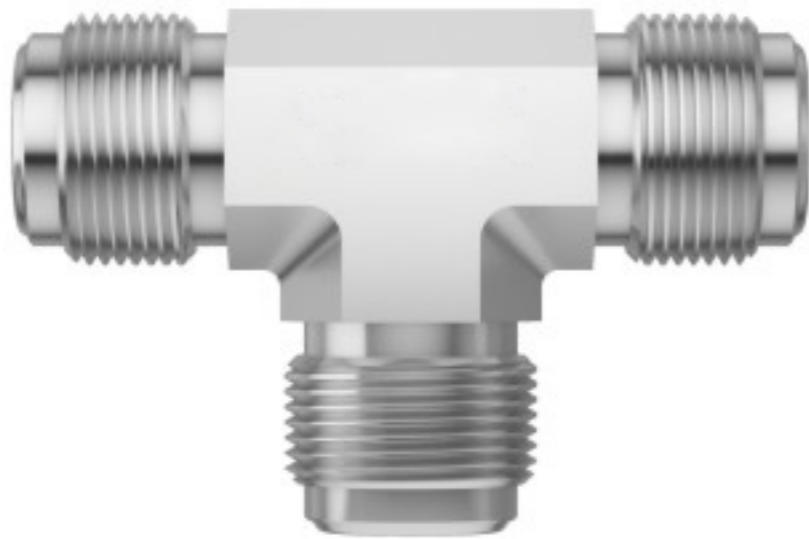

产品型号	VCR 尺寸 (in.)	尺寸 (mm)			工作压力 psig(bar)	
		L	E	F	6L	NI
TUT2S	1/8	22.6	2.3	11.1	11200(772)	9000(620)
TUT4S	1/4	27.2	4.6	12.7	10000(690)	8000(551)
TUT8S	1/2	36.8	10.2	20.6	4300(296)	3500(241)
TUT12S	3/4	48.8	15.7	31.8	3700(254)	3000(206)
TUT16S	1	50.8	22.1	42.9	3000(206)	2400(165)

## TUC 四通接头

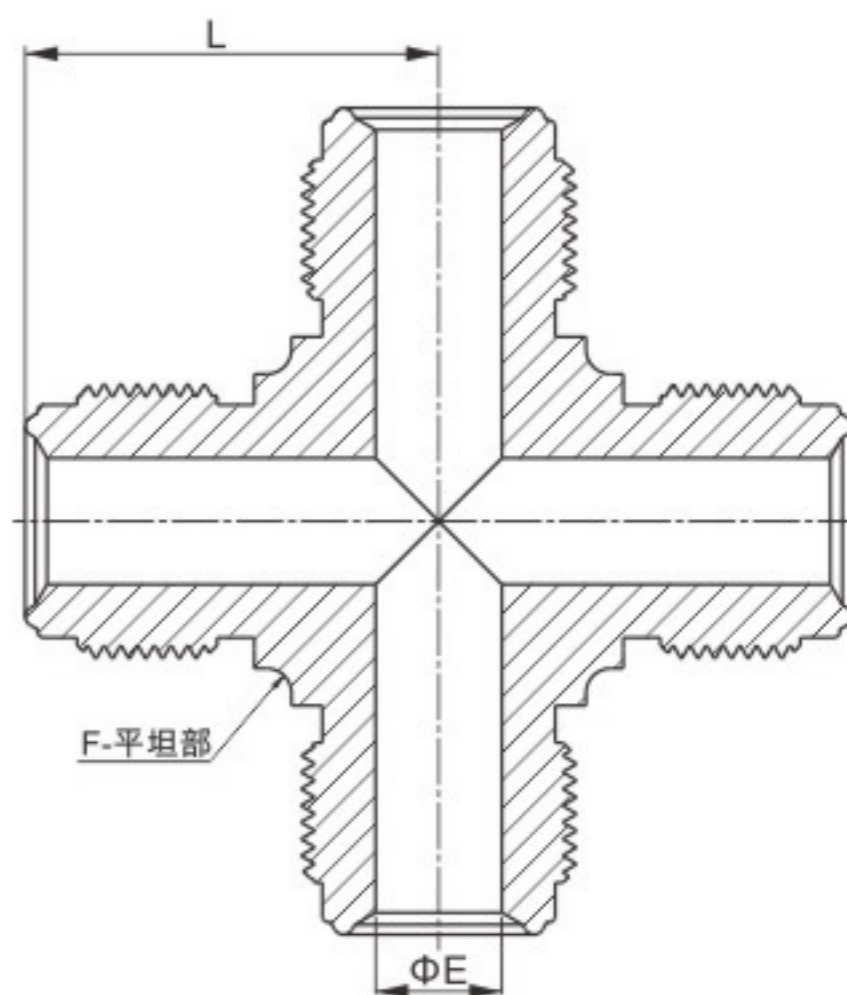

英制

产品型号	VCR 尺寸 (in.)	尺寸 (mm)			工作压力 psig(bar)	
		L	E	F	6L	NI
TUC2S	1/8	22.6	2.3	11.1	11200(772)	9000(620)
TUC4S	1/4	27.2	4.6	12.7	10000(690)	8000(551)
TUC8S	1/2	36.8	10.2	20.6	4300(296)	3500(241)
TUC12S	3/4	48.8	15.7	31.8	3700(254)	3000(206)
TUC16S	1	50.8	22.1	42.9	3000(206)	2400(165)

## TWMCN NPT阳螺纹焊接接管

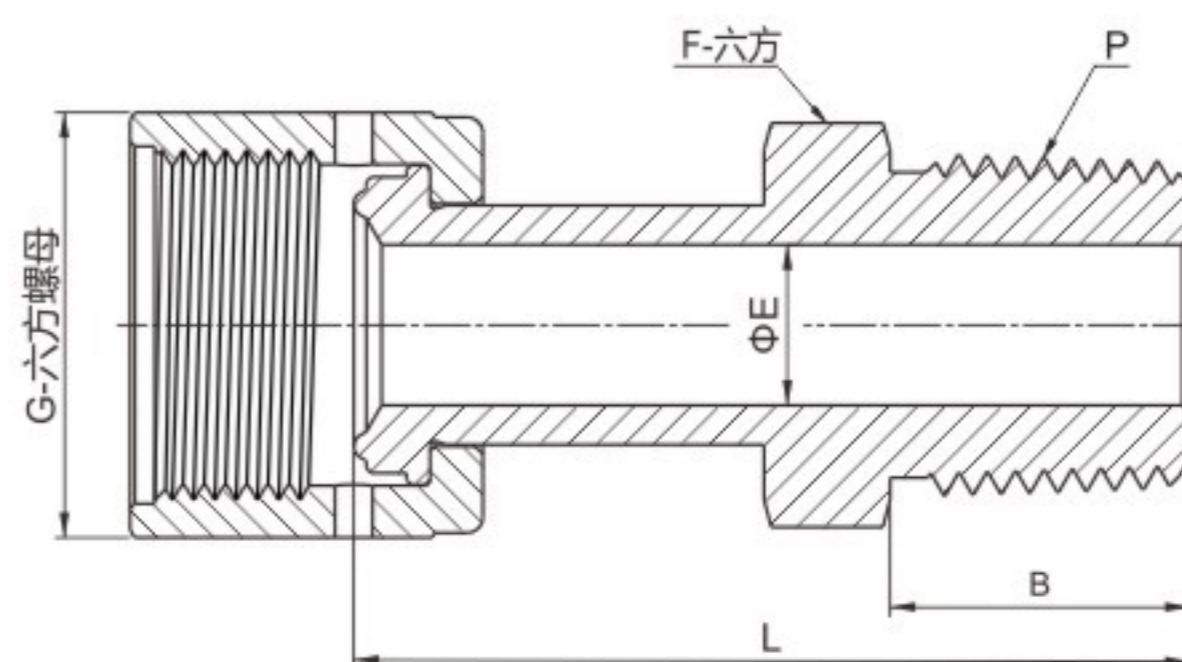
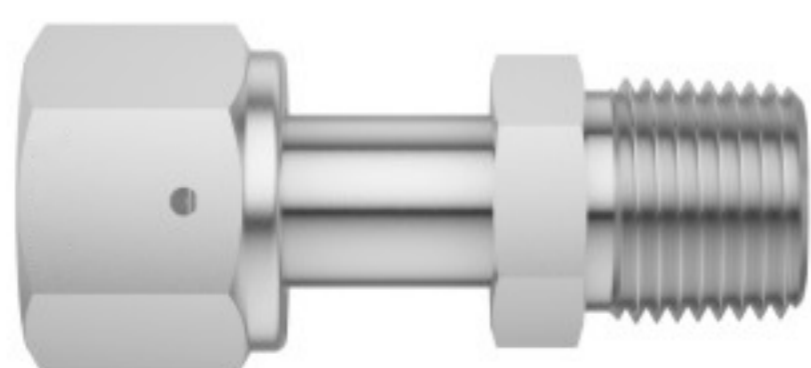

产品型号	VCR 尺寸 (in.)	P-NPT 螺纹规格	尺寸 (mm)					工作压力 psig (bar)	
			L	B	E	F	G	6L	NI
TWMCN42S	1/4	1/8	40.1	9.7	4.6	11.1	19.1	8000(551)	8000(551)
TWMCN44S	1/4	1/4	45.5	14.2	4.6	14.3	19.1	8000(551)	8000(551)
TWMCN82S	1/2	1/8	48.0	14.2	10.2	17.5	27.0	4300(296)	3500(241)
TWMCN88S	1/2	1/2	53.1	19.1	10.2	22.2	27.0	4300(296)	3500(241)

## TWFCN NPT阴螺纹焊接接管

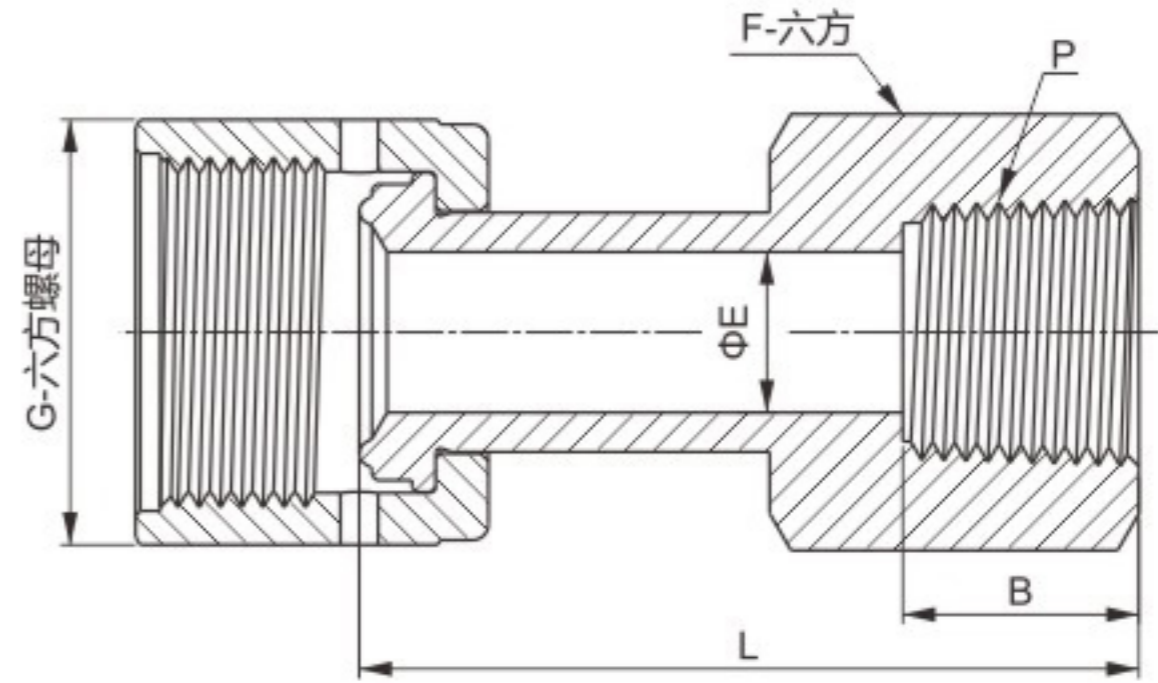
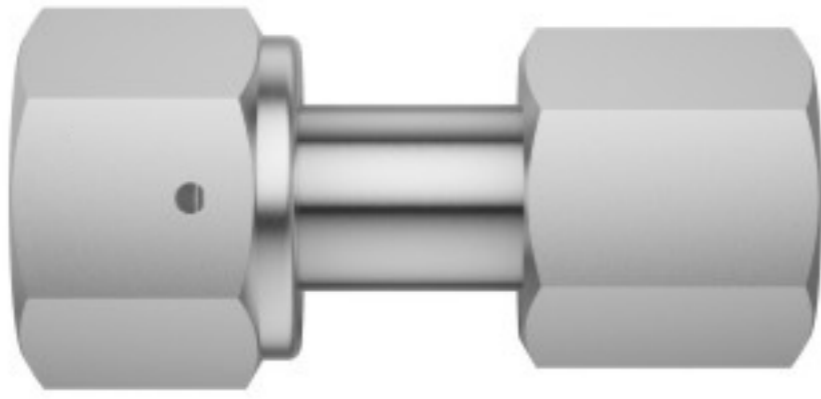

产品型号	VCR 尺寸 (in.)	P-NPT 螺纹规格	尺寸 (mm)					工作压力 psig (bar)	
			L	B	E	F	G	6L	NI
TWFCN44S	1/4	1/4	45.0	15.0	4.6	19.1	19.1	6600(454)	6600(454)
TWFCN86S	1/2	3/8	49.5	15.0	10.2	22.2	27.0	4300(296)	3500(241)
TWFCN88S	1/2	1/2	55.4	19.8	10.2	27.0	27.0	4300(296)	3500(241)

## TWLC 卡套焊接接管

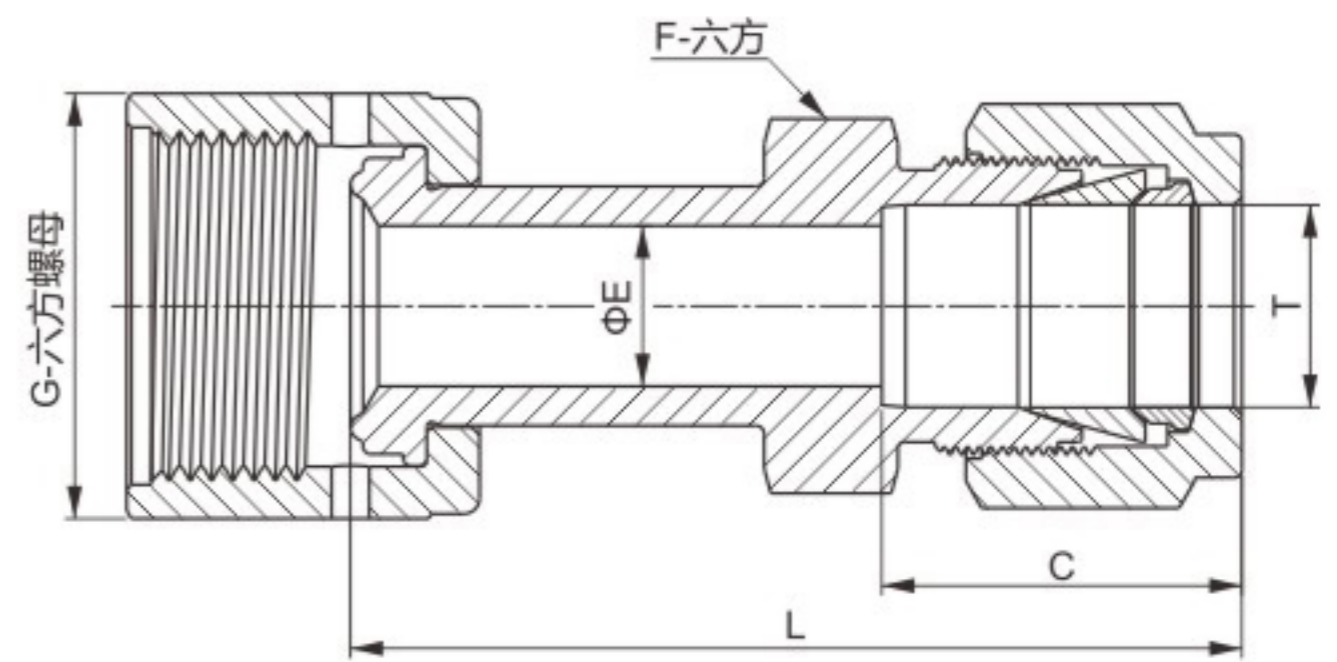
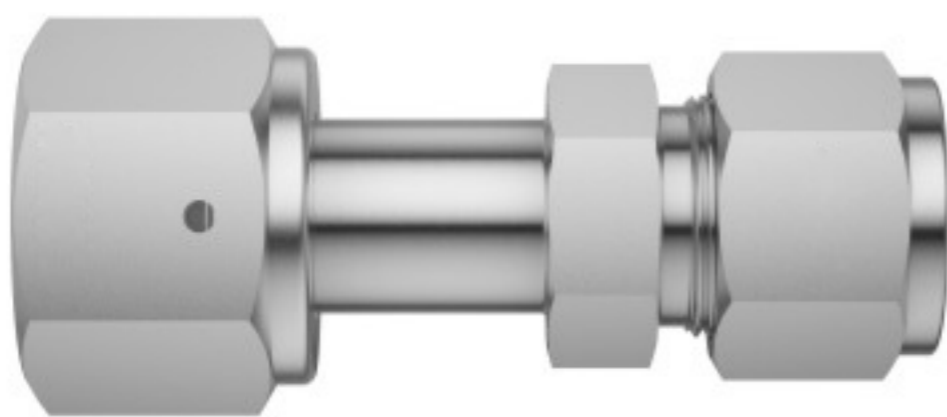

英制

产品型号	VCR 尺寸 (in.)	T-Tube管 外径(in.)	尺寸 (mm)					工作压力 psig (bar)	
			L	C	E	F	G	6L	NI
TWLC44S	1/4	1/4	49.3	15.2	4.6	12.7	19.1	8000(551)	8000(551)
TWLC46S	1/4	3/8	50.0	16.8	4.6	15.9	19.1	6500(447)	6500(447)
TWLC88S	1/2	1/2	56.6	22.9	10.2	20.6	27.0	4300(296)	3500(241)

## TWFU

焊接接管直通

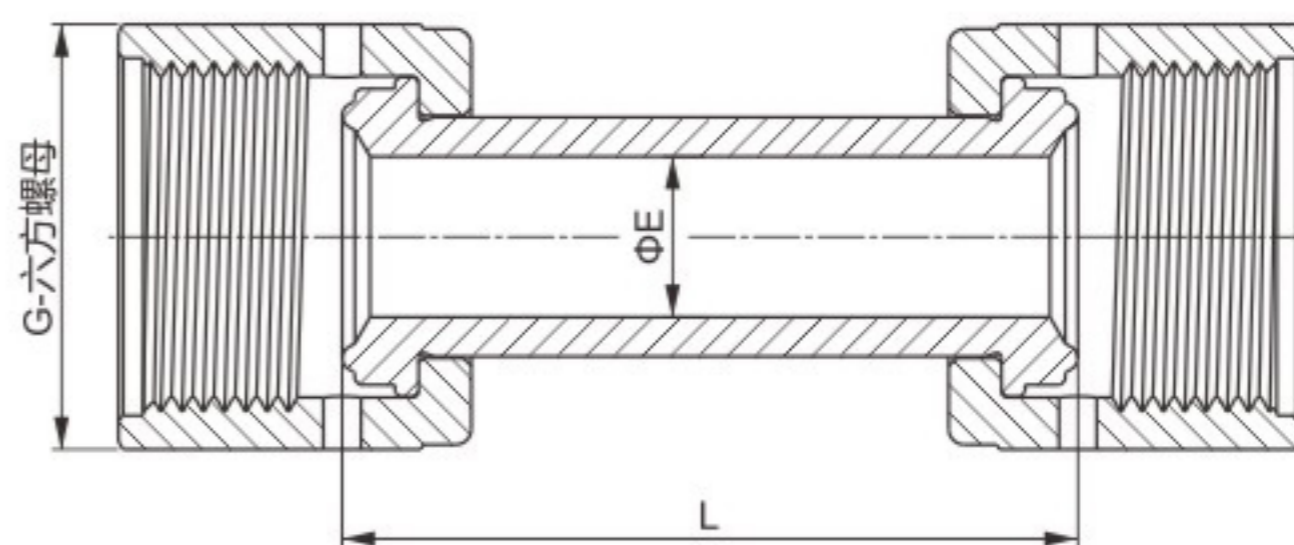
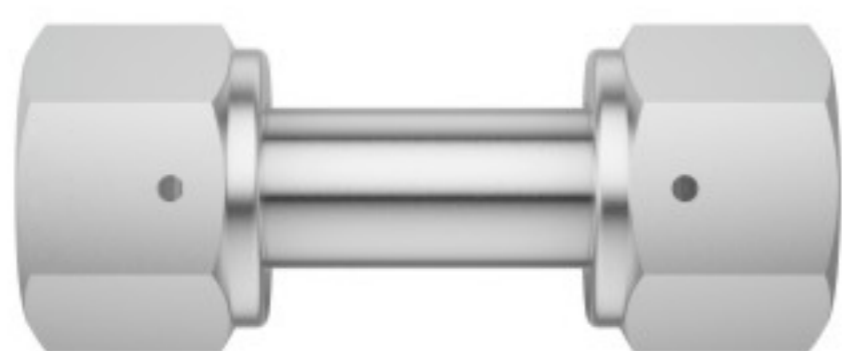

产品型号	VCR 尺寸 (in.)	尺寸 (mm)			工作压力 psig (bar)	
		L	E	G	6L	NI
TWFU4S	1/4	43.4	4.6	19.1	8000(551)	8000(551)
TWFU8S	1/2	46.7	10.2	27.0	4300(296)	3500(241)

## TFEU

阴螺纹弯头

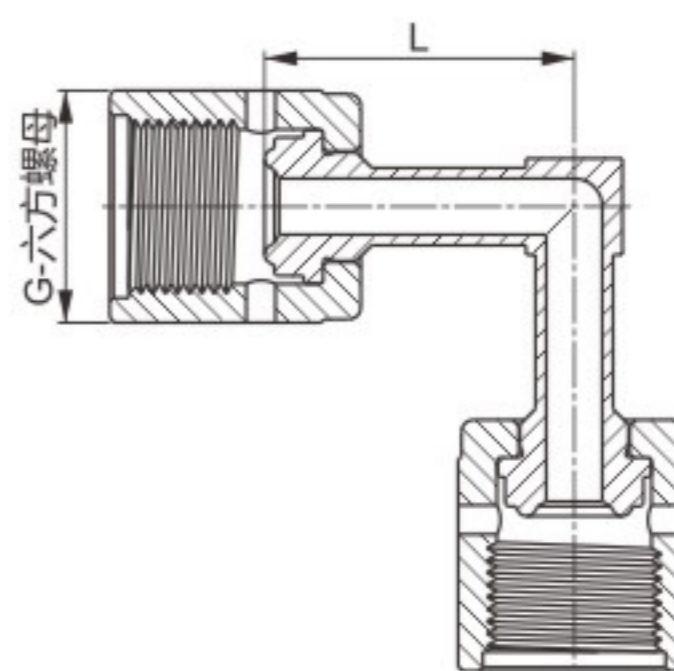

产品型号	VCR 尺寸 (in.)	尺寸 (mm)		工作压力 psig (bar)	
		L	G	6L	NI
TFEU4S	1/4	25.4	19.1	8000(551)	8000(551)

**TFTU**  
阴螺纹三通

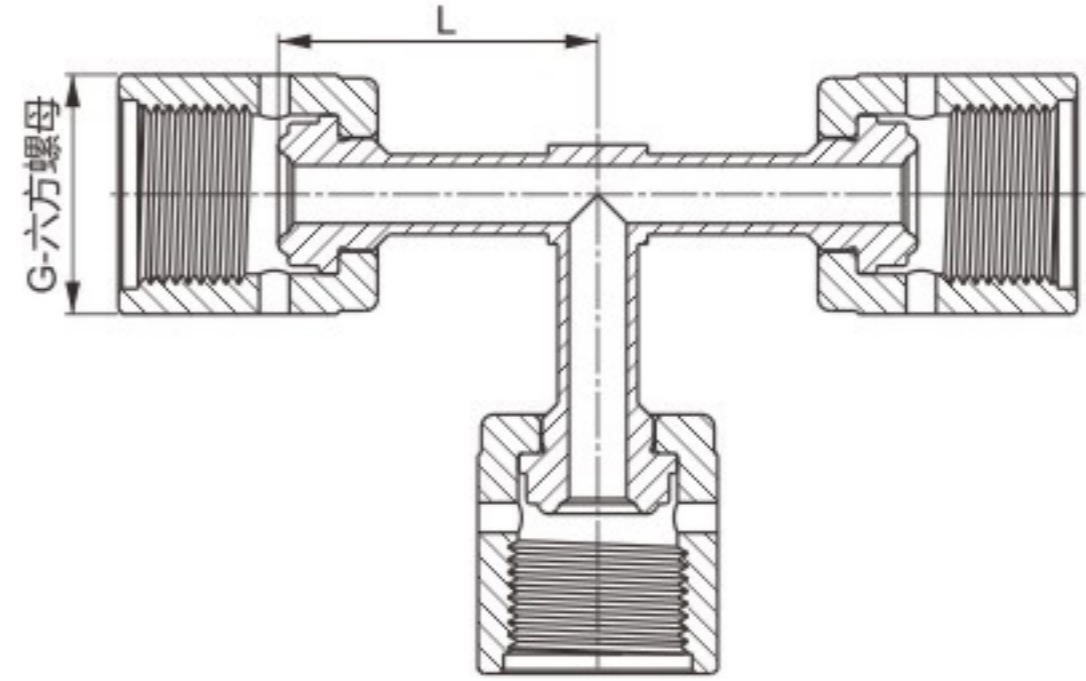

产品型号	VCR 尺寸 (in.)	尺寸 (mm)		工作压力 psig (bar)	
		L	G	6L	NI
TFTU4S	1/4	25.4	19.1	8000(551)	8000(551)

**TFN**  
阴螺纹螺母

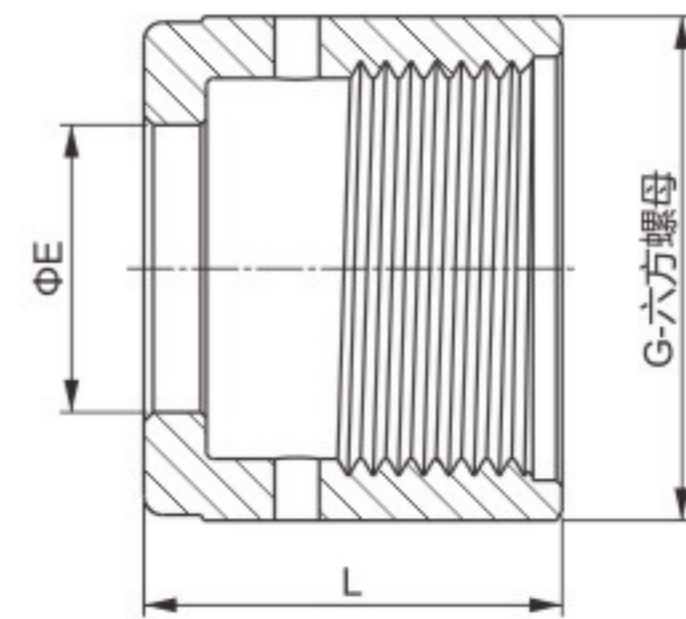

产品型号	VCR 尺寸 (in.)	尺寸 (mm)		
		L	E	G
TFN2S	1/8	13.5	5.3	11.1
TFN4S	1/4	20.6	9.1	19.1
TFN8S	1/2	22.4	15.5	27.0
TFN12S	3/4	28.4	22.6	38.1
TFN16S	1	34.0	30.5	44.5

**TMN**  
阳螺纹螺母

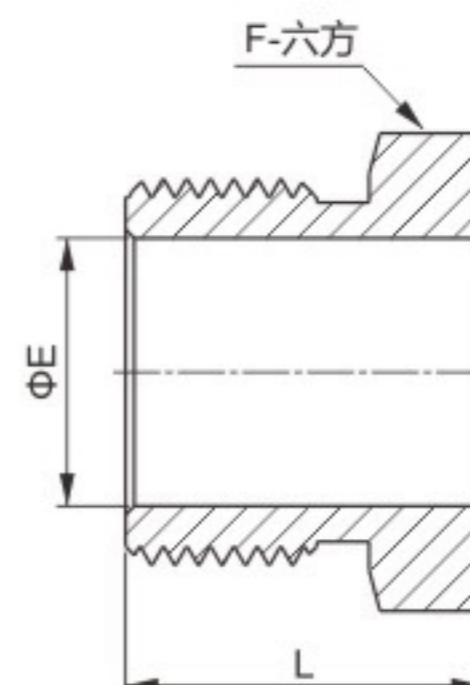

产品型号	VCR 尺寸 (in.)	尺寸 (mm)		
		L	E	F
TMN2S	1/8	12.7	5.3	9.5
TMN4S	1/4	18.0	9.1	15.9
TMN8S	1/2	20.6	15.5	23.8
TMN12S	3/4	25.4	22.6	33.3
TMN16S	1	30.2	30.5	41.3

**TPG**  
堵头

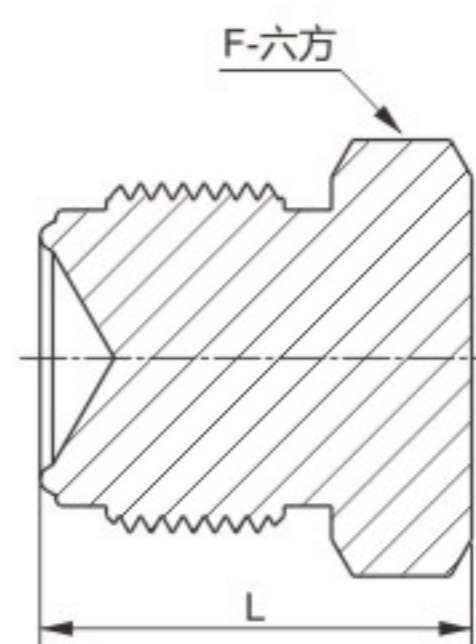
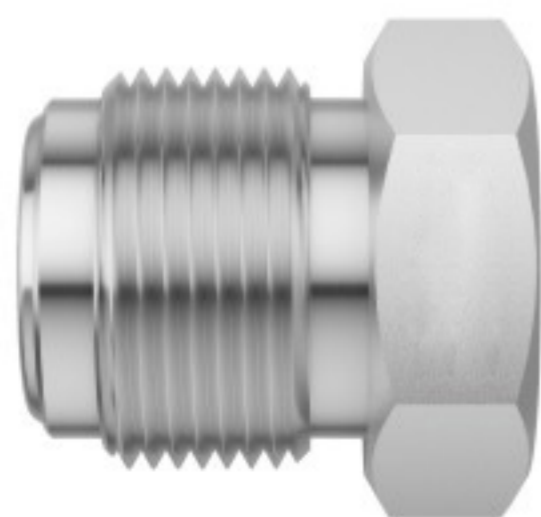

产品型号	VCR 尺寸 (in.)	尺寸 (mm)	
		L	F
TPG2S	1/8	17.3	9.5
TPG4S	1/4	23.4	15.9
TPG8S	1/2	27.4	23.8
TPG12S	3/4	36.3	33.3
TPG16S	1	38.6	41.3

**TCP**  
堵帽

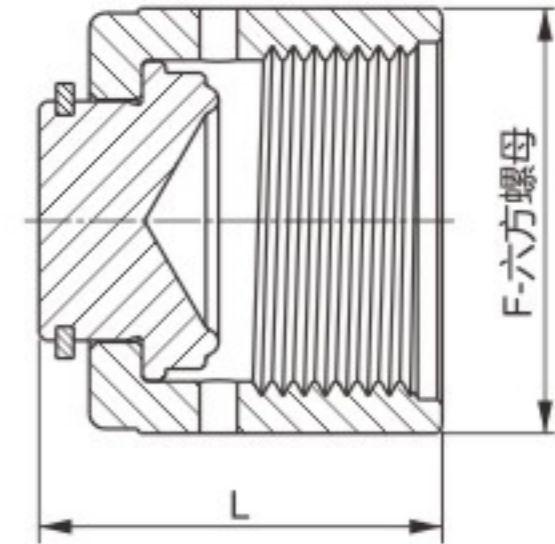
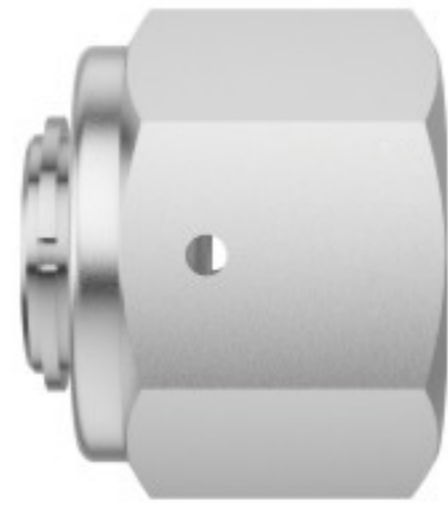

产品型号	VCR 尺寸 (in.)	尺寸 (mm)	
		L	F
TCP2S	1/8	16.0	11.1
TCP4S	1/4	23.9	19.1
TCP8S	1/2	25.6	27.0
TCP12S	3/4	32.8	38.1
TCP16S	1	39.1	44.5

**TGT**  
平垫片

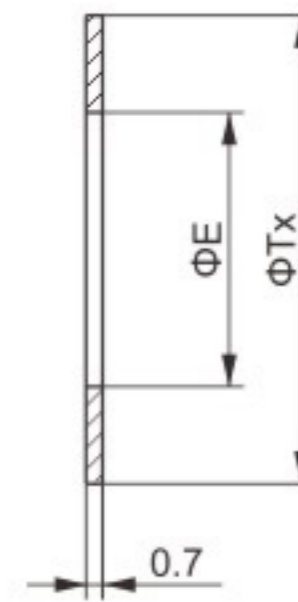

产品型号	VCR 尺寸 (in.)	尺寸 (mm)	
		Tx	E
TGT2S	1/8	6.6	2.3
TGT4S	1/4	11.9	5.6
TGT8S	1/2	19.8	11.2
TGT12S	3/4	29.0	16.8
TGT16S	1	35.6	22.6

## TGR 支撑垫片组件

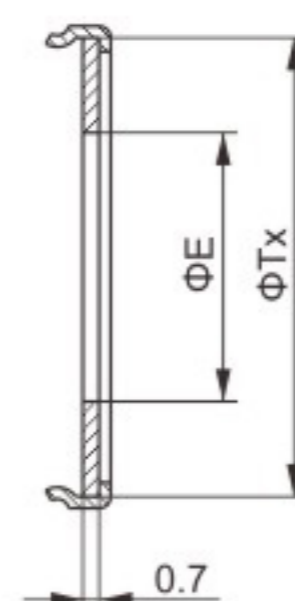

产品型号	VCR 尺寸 (in.)	尺寸 (mm)	
		Tx	E
TGR4S	1/4	12.7	6.1
TGR8S	1/2	20.1	11.2
TGR12S	3/4	29.0	16.8
TGR16S	1	35.6	22.6

## TGSL 侧载安装支撑垫片

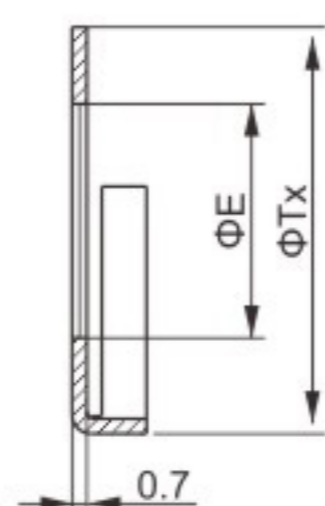

产品型号	VCR 尺寸 (in.)	尺寸 (mm)	
		Tx	E
TGSL4S	1/4	11.4	6.1
TGSL8S	1/2	19.1	11.0

## TBG 盲垫片

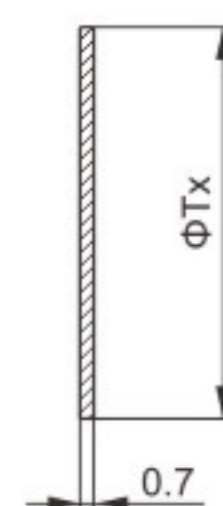

产品型号	VCR 尺寸 (in.)	尺寸 (mm)
		Tx
TBG2S	1/8	6.6
TBG4S	1/4	11.9
TBG8S	1/2	19.8
TBG12S	3/4	29.0
TBG16S	1	35.6